

Contents lists available at [ScienceDirect](http://www.sciencedirect.com)

South African Journal of Chemical Engineering

journal homepage: <http://www.journals.elsevier.com/south-african-journal-of-chemical-engineering>

# Effect of sieve tray hole diameter on the efficiency of a vibrating plate extractor



Nomakhosi D. Sincuba<sup>a</sup>, Sudesh Rathilal<sup>a,\*</sup>, Milan Carsky<sup>b</sup>

<sup>a</sup> Durban University of Technology, Department of Chemical Engineering, P.O. Box 1334, Durban 4000, South Africa

<sup>b</sup> University of Kwazulu Natal, Howard College, School of Engineering, Durban, South Africa

## ARTICLE INFO

### Article history:

Received 15 November 2016

Received in revised form

1 December 2016

Accepted 20 January 2017

### Keywords:

Vibrating plate extractor

Sieve tray hole diameter

Drop size distribution

Sauter mean diameter

Liquid–liquid extraction

## ABSTRACT

The acetone-toluene-water system was studied in a 4.77 cm ID vibrating plate liquid–liquid extraction column (VPE) with a total number of 31 sieve trays. The effect of agitation level (product of frequency and amplitude of vibration) and sieve tray hole diameter on the dispersed phase holdup, drop size distribution and Sauter mean diameter was studied. Normally, the mean drop diameter decreases more rapidly with an increase in the agitation levels and as the sieve tray hole diameter decreases. The dispersed phase holdup in a mixer settler decreased as the agitation level increased until a minimum dispersed phase holdup was reached at the agitation level of 3.75 mm/s. During the dispersion regime, as the agitation level increased the dispersed phase holdup was increased. The drop size and Sauter mean diameter were correlated to the agitation level, whereas, the dispersed phase holdup was correlated to the operating regimes (mixer settler regime and dispersion regime) of the VPE. Sieve trays with a hole diameter of 3.00 mm was the most effective from the ones studied.

© 2017 The Authors. Published by Elsevier B.V. on behalf of Institution of Chemical Engineers. This is an open access article under the CC BY-NC-ND license (<http://creativecommons.org/licenses/by-nc-nd/4.0/>).

## 1. Introduction

Liquid–liquid extraction is the second most important separation process largely used by many industries after distillation (Tsouris et al., 1994; Usman et al., 2008). Although the operation principles and dynamics of this process are well understood, increasingly stringent environment regulations, increasing cost of raw materials, high quality products and needs to reduce operational costs are required for good performance.

The main aspect of liquid–liquid extraction is the efficiency of mass transfer between two liquids. For mass transfer to take place between the two liquids there needs to be sufficient contact between the phases. To achieve this, agitated columns are used. Agitated columns are preferred to static columns because of the mixing level that is achieved in them (Seader and Henley, 2006). It is in this area that more research is still being conducted and continues to be significant.

This study mainly entails the research conducted using a vibrating plate extraction column (VPE). Literature review divulges that most research work has been carried out using mechanically agitated columns, however, it is limited when it comes to reciprocating plate columns and vibrating plate extractors (Rathilal et al., 2011). Reciprocating plate columns have the higher efficiency and higher throughput compared to other agitated columns (Prabhakar et al., 1988). The VPE is a modification of a reciprocating plate column (RPC).

The only difference between these two columns is the design and function of the sieve trays that are used. The sieve tray in the VPE has smaller holes compared to the RPC. The VPE tray has downcomers while the RPC does not. The small holes facilitate the movement of the dispersed phase and the downcomers facilitate the movement of the continuous phase in the VPE. However, in the RPC both phases share the same holes. The main advantage of the VPE over the RPC is that it

\* Corresponding author.

E-mail address: [rathilals@dut.ac.za](mailto:rathilals@dut.ac.za) (S. Rathilal).

<http://dx.doi.org/10.1016/j.sajce.2017.01.002>

1026-9185/© 2017 The Authors. Published by Elsevier B.V. on behalf of Institution of Chemical Engineers. This is an open access article under the CC BY-NC-ND license (<http://creativecommons.org/licenses/by-nc-nd/4.0/>).

has a capability of operating at relatively low agitation levels (product of amplitude and frequency of vibration) and achieve high throughput while RPC can only operate at high agitation levels. Thus VPE is characterised by lower mechanical stress and energy usage.

To achieve the highest separation efficiency in the vibrating plate extractor, there are many adjustable parameters that can be manipulated, such as, sieve tray hole diameter and the agitation levels. These parameters can affect both the mass transfer and hydrodynamic performance of the column. The determination of these parameters is crucial in achieving the highest separation efficiency in the VPE. The main focus of this study was to investigate the effects of these parameters on the separation efficiency of the vibrating plate extractor.

## 2. Experimental test system and methodological approach

The acetone-toluene-water system was used to conduct the experimental work on a 4.77 cm ID VPE. This is a standard test system for liquid–liquid extraction recommended by the European Federation of Chemical Engineering (EFCE, 1985) due to its high accuracy especially when gas chromatography is used. Three sieve tray hole diameters were used to test which is the most effective. The details of the three tray designs are stipulated in Table 1 below. Fig. 1 shows a schematic diagram of the experimental setup.

The mass transfer experiments were conducted to determine if the mass transfer affects the hydrodynamics of the column. A feed mixture of 6 wt.% acetone in toluene solution was used. The experiments were conducted for a solvent/feed ratio of 1:1 at a tray spacing of 150 mm and the total throughput was kept constant at 30 L/h.

## 3. Experimental procedure

A concentration of 6 wt.% acetone in toluene solution was fed at the bottom of the column and moved up the column as the dispersed phase. Water was used as the extraction solvent, fed at the top of the column and flowed down through downcomers as a continuous phase. The interface was located at the top settling tank due to the fact that the dispersed phase was the light phase. The column was initially filled with the continuous phase (water). Dispersed droplets were allowed to rise through the column and through perforations of the trays. The plate stack was vibrated using a vibrating motor that was

located at the top of the column. Vibrating frequency was varied from 0.5 to 3 Hz with increments of 0.5 Hz while vibrating amplitude was kept constant at 2.5 mm.

A conductivity probe was used to control the interface level in the top settling tank by varying the rate at which the extract was removed from the column. The interface level was set at a fixed measured level below the raffinate overflow point. The agitation level was set to the required value by adjusting the frequency on the vibration motor controller. Steady state of the system was achieved in 45 min (Rathilal, 2010). A Perspex box filled with water was attached around the column between 2 plates where photographs of the droplets were taken. This box helped to reduce the effect of the curvature of the column on the size of the droplets. The drop sizes were measured using photographic techniques with the aid of Image Pro Plus software. Sauter mean diameter,  $d_{32}$ , was estimated from drop size distributions.

The dispersed phase hold-up was measured by measuring the difference of the interface level when the inlets and outlets were stopped and the dispersed phase droplets were allowed to coalesce and accumulate in the top settling tank.

The percentage amount of acetone extracted was measured by analysing feed samples and the raffinate sample using the gas chromatograph. The percentage of acetone extracted was estimated using the following formula:

$$\text{Percentage acetone extracted} = \frac{x_f - x_r}{x_f} \times 100 \quad (1)$$

Where  $x_f$  and  $x_r$  are the mass fractions of acetone in the feed and raffinate respectively. The formula was valid since the solvent to feed ratio was kept constant at 1:1.



## 4. Results

### 4.1. Dispersed phase holdup

The experimental results for all the sieve tray hole diameters were compared to determine if the dispersed phase holdup is affected by the sieve tray hole diameter used. The effect of the sieve tray hole diameter on the dispersed phase holdup is shown in Fig. 2 which shows similar trends for all three sieve trays.

The results show two distinct hydrodynamic flow regimes and a minimum dispersed phase holdup which occurs at 3.75 mm/s in all three trays. Similar trends were observed in literature during the dispersion regime (Rathilal et al., 2011).

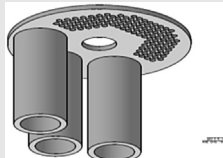
**Table 1 – Sieve Tray specifications.**

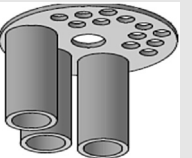
Tray	1	2	3
Tray diameter (mm)	47.4	47.4	47.4
Hole diameter (mm)	4.5	3	1.5
No of holes	12	28	98
Hole area (m <sup>2</sup> )	0.00020	0.00020	0.00020
Pitch	triangular	triangular	triangular
Material	Stainless steel	Stainless steel	Stainless steel
Pictures			

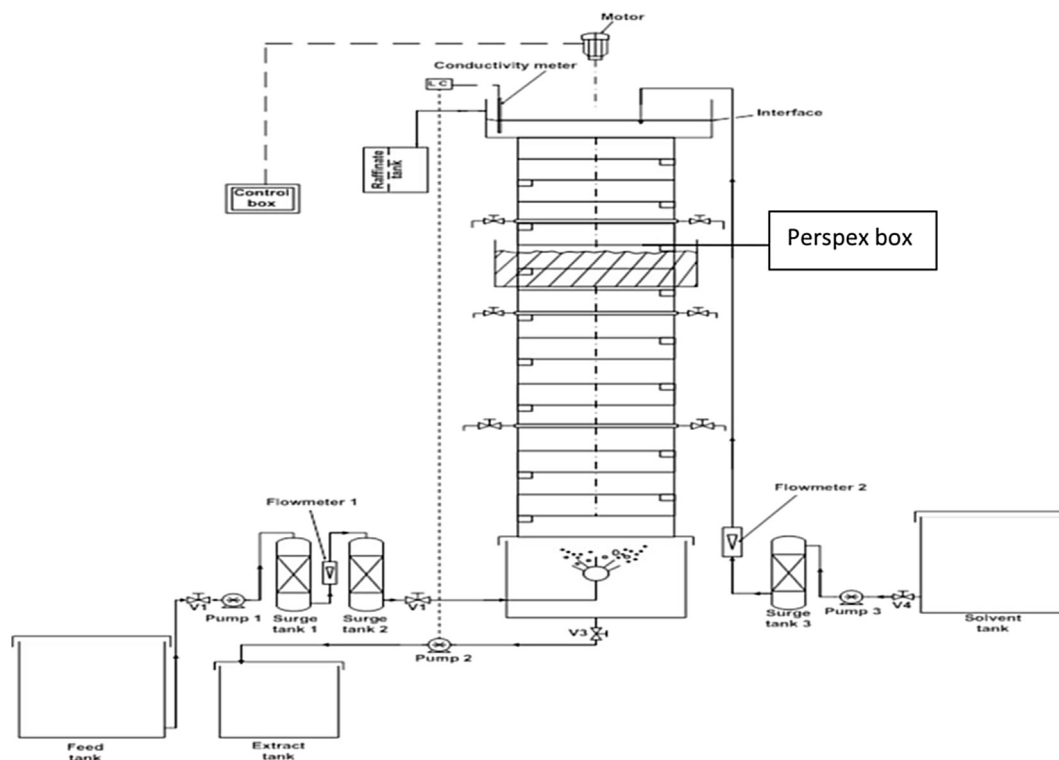

Fig. 1 – Schematic diagram of VPE.

The first flow regime is the mixer-settler regime where initially a high dispersed phase holdup was observed. This was attributed to the accumulation of a toluene layer under each tray in the column. As the agitation level is increased, this layer decreases, which corresponds to a decrease in the holdup (Rathilal et al., 2011, 2013; Sincuba et al., 2015; Aravamudan and Baird, 1999). After reaching a minimum holdup, the holdup started to increase with agitation level. This is due to the drag force acting on the droplets in relation to the buoyancy. Therefore, the velocity of the drops was decreased resulting in a higher residence time which causes a higher holdup (Camurdan, 1986; Taylor et al., 1982). Fig. 2 also shows high values of dispersed phase holdup when the smallest sieve tray hole diameter is used. This is due to the fact that as the hole diameter decreases smaller droplets are formed and more holes are available to form many small droplets. As the sieve tray hole diameter decreases the droplets become smaller and the smaller the droplets the higher the residence time and the higher the holdup.

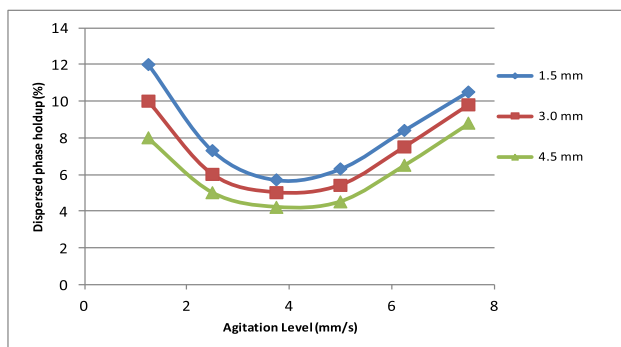

Fig. 2 – Effect of hole diameter on dispersed phase holdup.

Additionally, any further increase in the agitation level in the dispersion regime will lead to an exponential increase in the dispersed phase holdup, which drives the system to the emulsion flow regime. In this regime, the intense agitation levels cause the reduction in the coalescence of droplets therefore the rate of entry of the dispersed phase droplets exceeds the rate of coalescence of the droplets. This results in flooding of the column (Laddha and Degaleesan, 1983). Therefore, it is assumed that the emulsion regime is not favoured since the holdup is expected to increase in an unstable manner because of the flooding. According to Aravamudan and Baird (1999) the dispersed phase holdup is a key factor in determining the interfacial area for mass transfer as well as the indication of the onset of flooding.

#### 4.2. Sauter mean diameter

Fig. 3 shows the effect of the sieve tray hole diameter on the Sauter mean diameter. Drop size distribution results were used to determine the Sauter mean diameter according to

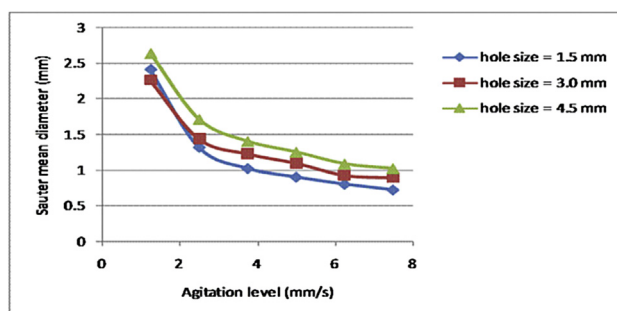

Fig. 3 – Effect of agitation level on Sauter mean diameter.

Rathilal et al. (2013). A decrease in the Sauter mean diameter as the agitation level increases is observed. This observation is achieved since at higher agitation levels, the plates vibrated much faster resulting in more energy being dissipated to the fluid, producing much smaller droplets. Also at higher agitation levels, the inertial and shear forces of the droplets increased as a result of the hindered coalescence of the droplets. Thus, it resulted in smaller size droplets and a smaller Sauter mean diameter (Lo and Prochazka, 1983; Lo et al., 1992). Fig. 3 also shows a lower value of Sauter mean diameter when the smallest hole diameter is used. This means that Sauter mean diameter is affected by the sieve hole diameter and the droplets are developed through the sieve hole diameter. These results show that the Sauter mean diameter is dependent on agitation level and on the sieve tray hole diameter.

#### 4.3. Effect of agitation level on the extent of mass transfer

Percentage of acetone extracted was calculated using the difference of the acetone concentration between raffinate and feed divided by the acetone concentration of the feed and expressed in the mass percentage form (Eq. (1)). The concentration of acetone was determined by analysing the raffinate and feed sample using gas chromatography. The effect of agitation level on the extent of mass transfer was determined by plotting the amount of acetone extracted versus the agitation level which is illustrated in Fig. 4 below.

Fig. 4 shows an increase in the amount of acetone extracted as the agitation level increases and shows a significant increase in the amount of acetone extracted when a sieve tray hole diameter of 1.5 and 3 mm is used. This effect may be contributed by a decrease in hole diameter from 4.5 to 3 mm which resulted in more holes and smaller droplets formed with a larger residence time. However, the effect of hole diameter was not found significant when the 1.5 mm sieve tray hole diameter was used. The interfacial area available for mass transfer was fully developed at the sieve tray hole diameter of 3 mm. There is no evidence of more acetone being extracted with a hole diameter less than 3 mm even though the dispersed phased holdup was high and the Sauter mean diameter was small. To manufacture the tray with 1.5 mm holes will be costlier since more holes are required and it may be more difficult to drill the small holes. The sieve tray hole diameter of 3.0 mm has marginally lower values of the

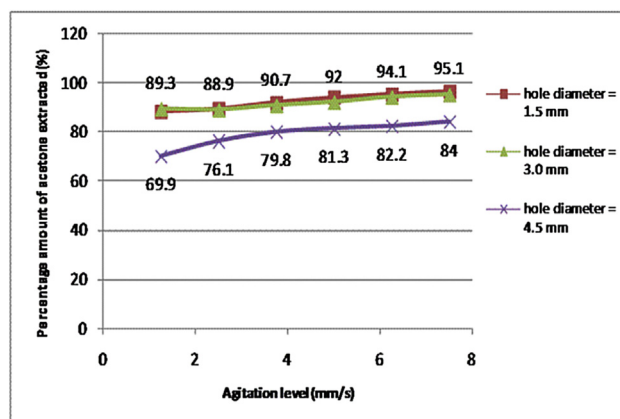

Fig. 4 – Effect of hole diameter on the amount of acetone extracted.

acetone extracted but may be cheaper and as such the cost of producing the smaller hole diameter trays cannot be justified. Therefore, it is recommended that the 3 mm diameter holes be used.

## 5. Conclusion

There is a significant effect of sieve tray hole diameter on the dispersed phase holdup. As the sieve tray hole diameter decreases the dispersed phase holdup increases. The droplet size is dependent on the sieve tray hole diameter. As the hole diameter increases the droplet size also increases and vice versa. Agitation level has a significant effect on mass transfer, as the agitation level increased the amount of the acetone extracted increases. The sieve tray hole diameter of 3.0 mm is recommended since it produces a relatively efficient process.

## Acknowledgments

Gratitude and appreciation is extended to National Research Foundation for financial support of this project.

## References

- Aravamudan, K., Baird, M.H.I., 1999. Effect of mass transfer on the hydrodynamic behavior of a Karr reciprocating plate column. *Ind. Eng. Chem. Res.* 38 (4), 1596–1604.
- Camurdan, M.C., 1986. Application of Adaptive Control to a Reciprocating Plate Liquid–Liquid Solvent Extraction Column. Open Access Dissertations and Theses, Paper 1068, Canada. EFCE (European Federation of Chemical Engineering), 1985. Standard Test System for Liquid Extraction. E Publications Series, 46, second ed.
- Laddha, G.S., Degaleesan, T.E., 1983. Dispersion and coalescence. In: Lo, T.C., Baird, M.H.I., Hanson, C. (Eds.), *Handbook of Solvent Extraction*, John Wiley & Sons, pp. 125–149. Chapter 4.
- Lo, T.C., Prochazka, J., 1983. Reciprocating-plate extraction columns. In: Lo, T.C., Baird, M.H.I., Hanson, C. (Eds.), *Handbook of Solvent Extraction*. John Wiley & Sons, pp. 373–390. Chapter 12.
- Lo, T.C., Baird, M.H.I., Rama Rao, N.V., 1992. The reciprocating plate column-development and applications. *Chem. Eng. Commun.* 116, 67–88.
- Prabhakar, A., Sriniketan, G., Varma, Y.B.G., 1988. Dispersed phase holdup and drop size distribution in pulsed plate columns. *Can. J. Chem. Eng.* 66 (2), 232–240.
- Rathilal, S., 2010. Modelling of a Vibrating-plate Extraction Column (Ph.D. thesis). University of KwaZulu-Natal, Durban.
- Rathilal, S., Carsky, M., Heyberger, A., Rouskova, M., 2011. Correlations for the prediction of NTU and mass transfer coefficient for a VPE. *South Afr. J. Chem. Eng.* 16 (1), 30–49.
- Rathilal, S., Carsky, M., Heyberger, A., Rouskova, M., 2013. Difference of hydrodynamics for a VPE with and without mass transfer and effect of agitation level on extent of mass transfer. *South Afr. J. Chem. Eng.* 18 (2), 29–39.
- Seader, J.D., Henley, E.J., 2006. *Separation Process Principles*, second ed. John Wiley & Sons. Chapter 4: 131–136 and Chapter 8: 295–339.
- Sincuba, N.D., Rathilal, S., Carsky, M., 2015. Investigation of the effects of tray downcomer design on the efficiency of a vibrating plate extractor. *South Afr. J. Chem. Eng.* 20 (3), 1–10.
- Taylor, P.A., Baird, M.H.I., Kusuma, I., 1982. Computer control of holdup in a reciprocating plate extraction column. *Can. J. Chem. Eng.* 60, 556–565.
- Tsouris, C., Kirou, V.I., Tavlarides, L.L., 1994. Drop size distribution and holdup profiles in multistage extraction columns. *Am. Inst. Chem. Eng. J.* 40, 407–418.
- Usman, M.R., Rehman, L., Bashir, M., 2008. Drop size and drop size distribution in a pulsed sieve-plate extraction column. *Proc. Pak. Acad. Sci.* 45 (1), 41–46.