

# A Review of LCC-HVDC and VSC-HVDC Technologies and Applications

Oluwafemi E. Oni

Electrical, Electronic & Computer Engineering Discipline  
University of KwaZulu-Natal  
Durban, 4001, South Africa  
[maxiphem@yahoo.com](mailto:maxiphem@yahoo.com)

Innocent E. Davidson

Department of Electric Power Engineering  
Durban University of Technology  
Durban, 4001, South Africa  
[Davidson@ukzn.ac.za](mailto:Davidson@ukzn.ac.za)

Kamati N.I. Mbangula

Electrical Engineering Discipline  
University of KwaZulu-Natal  
Durban, 4001, South Africa  
[imbangula14@gmail.com](mailto:imbangula14@gmail.com)

**Abstract**—High Voltage Direct Current (HVDC) systems has been an alternative method of transmitting electric power from one location to another with some inherent advantages over AC transmission systems. The efficiency and rated power carrying capacity of direct current transmission lines highly depends on the converter used in transforming the current from one form to another (AC to DC and vice versa). A well configured converter reduces harmonics, increases power transfer capabilities, and reliability in that it offers high tolerance to fault along the line. Different HVDC converter topologies have been proposed, built and utilised all over the world. The two dominant types are the line commutated converter LCC and the voltage source converter VSC. This review paper evaluates these two types of converters, their operational characteristics, power rating capability, control capability and losses. The balance of the paper addresses their applications, advantages, limitations and latest developments with these technologies.

**Keywords**—Line commutated converter, Voltage source converter, HVDC.

## I. INTRODUCTION

The first electric generator was DC machine, as well as the first electric power transmission system by Thomas Edison [1, 2]. In the last few decades, High Voltage Direct Current (HVDC) technology has been used, due to some of its inherent benefits in long distance transmission application. It is widely used all over the world for bulk power delivery over long distances, interconnections of asynchronous systems, stability of AC lines, power control, long submarine transmission and renewable energy integration. Reduction in the right of way (ROW) is another edge over AC systems [3].

HVDC transmission system involve the use of converter for the conversion of AC to DC (rectifier) at the transmitting end, and converting the DC back to AC at the receiving end (inverter), [4]. This converter usually has a 12-pulse arrangement, of valves connected in a star-delta, star-star formation to the AC networks. A reactor, dc capacitor and AC filters are also part of the converter circuitry. The two ends of the converters are connected via DC transmission lines which can either be overhead cable or submarine cable or directly in

the same location as in the case of back to back configuration. Continuous progress in HVDC systems is linked to advances in the power electronics technologies for the fabrication of a highly efficient semiconductor devices for HVDC converter topology [5].

There are two dominant methods used in converting AC to DC and vice versa. These methods are the Line commutated converter LCC and the voltage source converter VSC. The success of these two technologies became possible with the development of power electronics devices [6, 7]. Before the power electronics was the transverter, electrolytic and the atmospheric converter, all these are part of the several attempts made for AC/DC conversion. These entire attempts failed due to some technical reasons and safety measures inherent in using them [8].

The invention of mercury-arc valves brought temporary success to AC/DC conversion which later became outdated. The mercury arc valve which operated then have either been scrapped or upgraded to semiconductor converter technology [9]. Semiconductors devices have been in used since 1970s and are still a growing technology because of the high switching capacity and ability to withstand high current rating. Examples are the diode, diac, triac, thyristors, MOS-controlled thyristors (MCTs) [10], insulated-gate bipolar transistors (IGBT) and integrated gate-commutated thyristors (IGCTs) etc. [11].

This paper looks critically into the two dominant HVDC converter technologies taking into consideration their operational characteristic and their output AC waveform when subjected to three-phase short circuit as well as dc line fault. The simulation is carried out on DigSILENT Powerfactory and the results of each technology are compared alongside each other.

## II. CONVERTER CONFIGURATION AND TOPOLOGY

HVDC interconnections can be configured in different forms to suit different desired performance and operational requirements, namely:

- Back to back connection: This has both the inverter and the rectifier in the same location, and the valves are normally in the same building. It therefore has a short dc line of few meters located inside the same environment.
- Monopolar connection: This has both converters separated by a single dc pole line, either positive or negative voltage. The ground is used as a current return path. Most submarine cable connections use monopolar systems.
- Homopolar connection: This has two or more dc line of the same polarity connected to the converters. Negate polarity is normally used for less corona and reactive power loss. Ground is used as the return path. It works as a monopole when one pole develop a fault. The disadvantage of high cost make it unpopular and seldom used.
- Bipolar connection: This is the most popular method in HVDC interconnection of converters. It is similar to the homopolar connection, but it has different polarities. Each pole is independent, that is, it can operate with a single pole with ground used as return path [3].
- Multi-terminal connection: This has more than two sets of converters operating independently. Each converters can operate as a rectifier or an inverter [12].

#### A. COMPONENTS OF A CONVERTER STATION

- Converter transformer: LCC HVDC uses special type of transformer different from the AC transformer in that it has special features such as on load tap changes and follow different configuration. For example, the 12-pulse converter can follow six single-phase two windings, three single phase three winding or two three-phase two windings configuration to suit specification and operational performance [13, 14]. But the VSC HVDC uses same transformer as the normal AC transformer.
- Smoothing Reactors: This is used for removal of ripples of the DC current. It is also used to limit the rate of rise of the fault current on the DC line.
- Harmonic filters: These are connected to the converter terminals to provide a low impedance path to ground for removal of harmonics current. Filter used also provide the AC line with the reactive power compensation.

### III. LINE COMMUTATED CONVERTER (LCC-HVDC)

LCC, also known as a current source converter CSC uses a thyristors base technology for its converter. The thyristors is a silicon semiconductor devices with four layers of N and P type material acting as a bi-stable switches, triggered on with a gate pulse and stayed in that on condition until the next current zero crossing. In other for LCC to commute, the converters require a very high synchronous voltage source, thereby hindering it use for a black start operation. With LCC current rating reaching up to 6250A and blocking voltage of 10KV, this make LCC to have the highest voltage and power rating level of all the HVDC converter technologies [15-17].

LCC achieves its control by regulating the firing angle  $\bar{\alpha}$  on both rectifier and inverting side. It has an approach that utilizes

TABLE I. RECENT LCC –HVDC PROJECTS

Project Name	Location	Characteristic			
		(MW)	(KV)	Year	(km)
UK - Netherlands		1000	±400	2011	260
Jinpin – Sunan	China	7200	±800	2012	2093
Mundra – Haryana	India	2500	±500	2012	960
Rio – Madeira	Brazil	800	100	2012	B-B
Rio – Madeira	Brazil	2x3150	±600	2013	2375
Xiluodu – Guangdong	China	6400	±500	2013	1251
Nuozhadu – Guangdong	China	5000	±800	2013	1451
Southern Hami – Zhengzhou	China	8000	±800	2014	2200
Biswanath – Agra	India	6000	±800	2014	1728
Xiluodu-Zhejiang	China	8000	±800	2014	1688
<b>Zhundong – Sichuan*</b>	<b>China</b>	<b>10000</b>	<b>±1100</b>	<b>2015</b>	<b>2600</b>

a uni-directional line commutated flow of DC current which is inject into a receiving AC network, thereby termed CSC because the output current is kept at a constant level [18]

Power reversal from one station to another is carried out by inverting the DC voltage polarity in both stations but the current direction remains constant. The technology operates with good reliability and minimal maintenance. It's the most suitable way of transmitting bulk power using high voltage transmission lines. These features make LCC technology the most popular among HVDC schemes [19].

Table 1 shows few of the recent LCC-based HVDC around the globe. Zhundong-Sichuan scheme has the highest voltage and power, and the longest distance, project in China [20].

### IV. VOLTAGE SOURCE CONVERTER (VSC-HVDC)

Voltage source converter uses insulated gate bipolar transistor IGBT technology. The current in this technology can both be switched on and off at any time independent of the AC voltage, that is, it creates its own AC voltages in case of blackstart [21]. Its converters operate at a high frequency with pulse width modulation PWM which allows simultaneous adjustment of the amplitude and phase angle of converter while keeping the voltage constant [22]. VSC has high degree of flexibility with inbuilt capability to control both its active and reactive power as shown in fig. 1, which makes it more useful in urban power network area [23].

This technology was develop in the 1990's with the first project commissioned by ABB, 1997 [9]. But due to its capacity limits, VSC-HVDC has not been able to make much edge over its contemporary LCC scheme due to low device rating, high power losses and high dielectric stress on equipment insulation. Its application is approaching 1800MW, 500KV. An example is the 1400MW, ±525KV Nordlink that interconnect the grid of Statnett in Norway and TenneT in Germany over a distance of 623km [24]. A lot of research is ongoing to override this limitation [25] and to have the ability to ride through fault [26]. Ref. [27] explain VSC control, modelling, simulation and stability analysis in power systems.

The basic building block of VSC-HVDC topology start with two-level converter [28, 29]. It is like a six-pulse bridge in

which IGBT with inverse-parallel diodes replaced the thyristors, and the dc smoothing reactor of LCC is replaced by DC capacitor as shown in fig. 2. It derives its name from the fact that it has a switching devices which are complementarily operated to generate two levels of voltage ( $+V_{dc}/2$  and  $-V_{dc}/2$ ) at the ac output terminal of the converter. This complementary operation only allows one switching devices to operate at a time, and the other is turned off. Simultaneous turning on of both two switching devices will lead to short circuit of the capacitor across the dc link which may destroy the converter switches due to over-current. With this topology, each semiconductors switch withstands the full voltage stress that is flowing in the link [30].

Prevention of the dc voltage from changing polarity is done by the diode that is connected in parallel to the IGBT, since the diode can only conduct when forward biased, thereby discharging the dc circuits. But the current flows in both direction, passing through either the IGBT or the diode [31].

It adopt the pulse width modulation (PWM) techniques to control the gate switching frequency of the IGBT, and to reduce the harmonic distortion generated by the converter. Due to high switching losses in the IGBTs as a result of the PWM which is switched on and off many times in a cycles, the overall transmission efficiency of a two-level converter is very poor compared to the LCC converter. Another major setback is that a high level of electromagnetic interference occur when two-level converter is used for a high voltage DC systems [32].

An attempt to reduce the poor harmonic distortion and to have a high efficient VSC converter, brings about the multi-level converter (which start from the three-level converter with three discrete voltage level).

It synthesizes more than two voltage level at the AC terminal of each phase as shown in fig. 3. Several types of multilevel converter have been mention and analyzed in the literature [33-35], such as the diode clamped, where diodes are used as clamped and the dc output is subdivided into switches by a capacitors.

With n-levels, there will be n+1 capacitors, and n-1 switch pair are required to work in a complementary manner to generate the output dc voltage. High efficiency for switching at fundamental frequency, low cost and a lesser number of components are some of its merits. However it suffer setback as its less attractive for high voltage transmission due to difficulty in charging and discharging of its dc capacitor, lack of modular index and large inductance stray in the clamping path which have effect on the converter switching characteristics [33, 34]. Flying capacitors multilevel converter is another type which made use of a pre-charged capacitor. Unlike the diode clamped, two or more switch can synthesize an output voltage at the ac output terminal of the converter, and has a phase redundancies which allows specific choice of capacitor to be charge or discharged for voltage balancing across different levels. It has the ability to control real and reactive power flow, and to ride through fault and voltage sag because of its large number of capacitors [35]. Nevertheless, as the level increases, so does the size of the capacitors, as it becomes bulky. Also the control to track the voltage for all the capacitor becomes complicated as it requires high frequency switches. The single phase full bridge is the building block for the cascaded H-bridge multilevel link. It has four switches connected to an isolated capacitor (separate dc source). Each H-link generate three voltage levels. Easy modularized layout package for the series H-bridges makes it cheap and quickly to fabricate. It also have more possible voltage-levels output than the dc source. Good for reactive power compensation. With good voltage balancing capability through adaptive control action. However, cascaded H-bridge conversion is not suitable for HVDC application because it H-bridge requires the use of many isolated DC sources in series [36].

Recently, a new alternative of VSC-HVDC circuits was proposed in 2003, at the University of Bundeswehr in Munich, Germany, by Prof. Rainer Marquardt [37, 38]. This converter topologies is based on series-connection of several sub-modules of two semiconductor switches and a capacitor. This topology is known as modular multilevel converter (MMC or M2C) as shown in the (fig 3). The converter can either adopt the half bridge cascaded or full-bridge connections for the arrangement of each sub modules. The half-bridge modular multilevel (HB-MMC) addresses some of the limitation encountered in the convectional VSC converter, such as the reduction in the magnitude of the transient dc fault current, converter scalable to the highest transmission voltage through addition of more levels, great reduction in the harmonic content and elimination of low-order harmonics which usually requires large filters, and losses reduced to approximately 1% per converter, all these features made HB-MMC to be widely adopted in recent years. But the HB-MMC freewheeling diodes is unable to stop AC grid contribution to the dc fault current which makes it in need of fast acting dc circuit breaker, else the excessive current stresses may damage the freewheeling diode. The recent technology that overrides the overcurrent fault condition of the HB-MMC is the full bridge multilevel converter (FB-MMC). Though, this technology increases semiconductor losses but the important feature of dc fault reverse blocking capability was achieved by the converter by blocking current flow in the converter switches during dc faults, thereby disallowing both active and reactive power

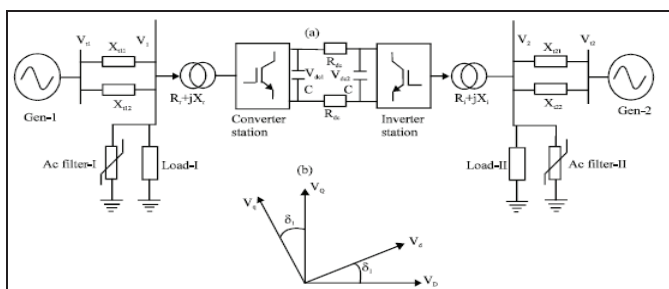

Fig. 1. VSC-HVDC scheme design

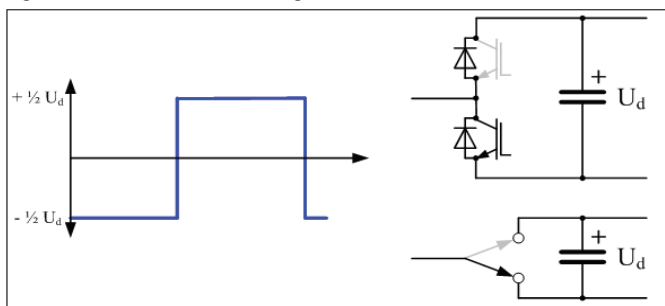

Fig. 2. Block diagram of a two-level VSC-HVDC



exchange that may want to occur between the dc systems and the ac grid [39, 40].

Other recent HVDC converter topologies with intrinsic dc fault ride-through capabilities are alternative arm modular multilevel (AA-MMC) converters and hybrid cascaded multilevel converter with ac side H-bridge cells. These converters achieve dc fault reverse blocking capability in order to eliminate ac grid contribution to dc side faults, but has little footprint and conversion losses compared to the H-bridge modular multilevel converter [39-41].

Independent control of power at each converter is possible, with one converter controlling the DC voltage at the link to match the nominal level and the other converter sets the amount of active power through the link. With the help of the phase reactor from the series inductance between the converter and the AC grid (fig 4), active and reactive power control was achieved as depict in (1) and (2).

$$P = \frac{U_{ac} U_{conv} \sin \delta}{X} \quad (1)$$

$$Q = \frac{U_{conv} (U_{conv} - U_{ac} \sin \delta)}{X} \quad (2)$$

X-represent the series reactance of the phase reactor and the transformer in the converter station.

Ability of VSC-HVDC to absorb and inject active and reactive power is shown in the P-Q-capability chart below (fig 4). This P-Q capability chart characteristic can be termed to a circle with a radius equal to the maximum MVA rating of the converters. Available reactive power depends on the active power transmitted which directly fall between the operating ranges of the converter MVA rating. The converters are restricted by the power electronics switches current rating and the capability circles. Vac is raised above the AC grid voltage to inject reactive power. The converter voltage however suffers restriction to the maximum rating of the power electronics which limit the capability chart for higher AC voltage.

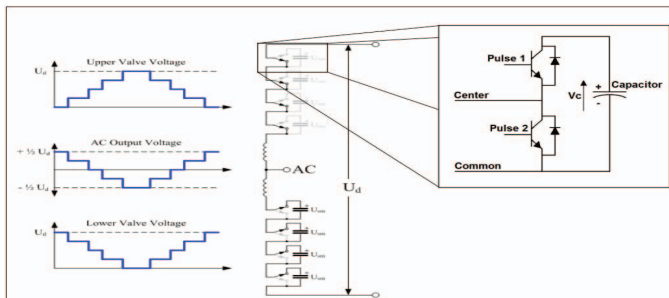

Fig. 3. Modular multilevel converter topology

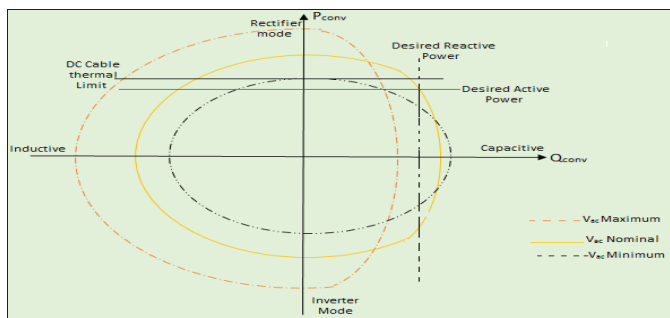

Fig. 4. simplified PQ characteristic of a VSC HVDC terminal [42]

Nevertheless, VSC remains the most suitable choice in transmitting renewable energy (such as: wind power and solar power) either offshore or onshore systems. Table II shows some existing VSC-HVDC installations.

TABLE II. SOME VSC-HVDC INSTALLATIONS

Project Name	Location	Characteristics			
		(KV)	Year	(MW)	(Km)
Borwin 1	Germany	±150	2009	400	200
Caprivi link	Namibia	±350	2010	300	951
Transbay	USA	±200	2010	400	85
EWIC	UK	±200	2012	500	261
Inelfe	France	±320	2013	1000	65
Skagerrak 4	Norway	±500	2014	700	244

TABLE III. A COMPARISON OF LCC AND VSC SCHEMES

LCC	VSC
Thyristor base technology	IGBT base technology
The semiconductor can with-stand voltage in either polarity	Withstand current in either direction
Constant current direction	Current direction changes with power
Energy is stored inductively	Store energy capacitively
Turned on by a gate pulse but rely on external circuit for its turn off	Both turn on and off is carried out without the help of an external circuit
High power capability	Lower power capability
Good overload capability	Has weak overload capability
Requires stronger AC systems for excellent performance	Operate well in a weak AC systems
Requires additional equipment for black start operation	Possesses black start capability
Requires AC and DC harmonic filters for removal of distortion and harmonics	Requires no filter because it generates an insignificant level of harmonics
Poor in reactive power control	Good reactive power control
Large site area, dominated by harmonic filters	A more compact site area
Requires converter transformer	Conventional transformer is used
Lower station losses	Higher station losses
More mature technology	Still at its infancy
Reversal of power is done by reversing the voltage polarity	Power is reverse by changing the current direction
Higher voltage capability of over 1000KV	Lower voltage capability of almost 600KV
Mostly used to transmit bulk power for a long distance	Used for transmitting power from remote area with renewable energy
Suffers commutation failures as a result of a sudden drop in the amplitude or phase shift in the AC voltage, which result in dc temporal over-current Though, the effect has no significant impact on the AC systems as it's a self-clearing effect within a few power frequency cycles.	Ability to turn on as well to be turned off of VSC makes it immune to any voltage dips or transient AC disturbance, therefore, it does not suffer commutation failure.
Commutation failures, need for change in dc polarity when converter want to change from rectifier to inverter mode make LCC HVDC more problematic to adopt in a multi-terminal HVDC system. Reason for low number of LCC base technology for multi-terminal HVDC.	Suitable for multi-terminal HVDC systems because it does suffer from commutation failures, has independent, multidirectional power flow, and operate with the same voltage polarity.
During short circuits on the dc line, control of the firing angle of the thyristors valves stops the increase of	Continuous conduction in the diode will cause an increase in dc fault current even when the IGBTs are

dc fault current. This converter control and protections reduces the damage caused by the fault current. Incased of overhead lines fault, power transmission is stopped for arc de-ionization, after which power transmission resumed.

turned off. The ac circuit breakers at both VSC HVDC ends must be opened to stop the diode conduction. The converter link must be re-started after fault has been removed.

TABLE IV. A COMPARISON OF THE THYRISTOR AND IGBT

Features	Thyristors	IGBT
Max. Voltage rating (V)	8000	1700
Voltage blocking	Sync/Async	Async.
Voltage blocking	Sync/Async	Async.
Gating	Pulse	Voltage
Conduction drop (V)	1.2	3
Switching frequency (KHz)	1	20
Development target maximum voltage rating (KV)	10	3.5
Development target maximum current rating (KA)	8	2

Fig. 5 shows an overview of HVDC projects around the world and fig. 6 depict HVDC available ratings for different transmission medium.

### V. FAULT CHARACTERISTIC OF LCC AND VSC

To slightly explain the transient response of LCC and VSC HVDC to faults in the AC network on the two side of the converters' end, both technologies are modelled using DigSILENT Powerfactory.

Fig 7 show the LCC HVDC setup. It's a bipolar HVDC systems, each pole consisting of twelve-pulse thyristors on both the inverter and rectifier side, with 1000MW of power at  $\pm 600\text{KV}$  transmitted per pole via 1000km overhead dc lines. An external grid is connected at both the rectifier and inverter end to supply and to receive power respectively.

VSC HVDC setup is modelled as shown in fig. 8. Each converter rated at 1000MW, 600KV via 1000km overhead lines.

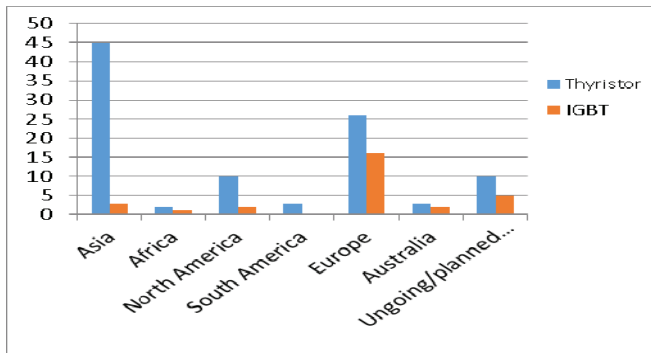

Fig. 5. Overview of HVDC projects around the world

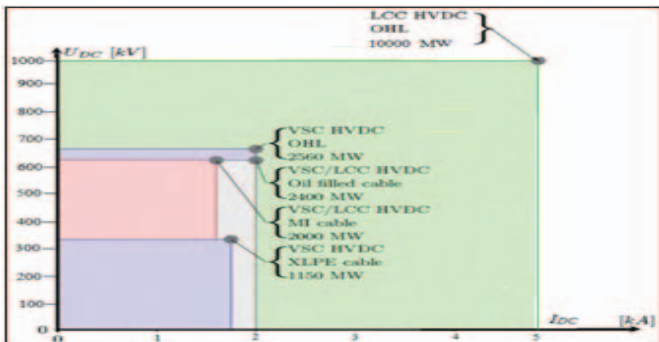

Fig. 6. Available ratings of HVDC systems ( $U_{DC}$  refers to voltage per pole, and  $I_{DC}$  is the current rating, in a bipolar setup,  $P=2U_{DC} I_{DC}$ [13]

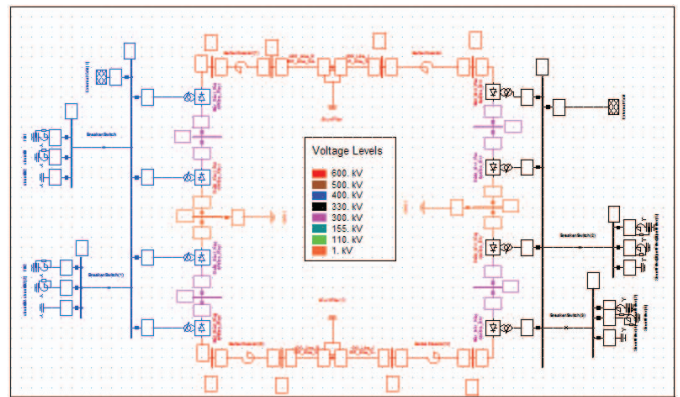

Fig. 7. LCC modelling on DigSILENT.

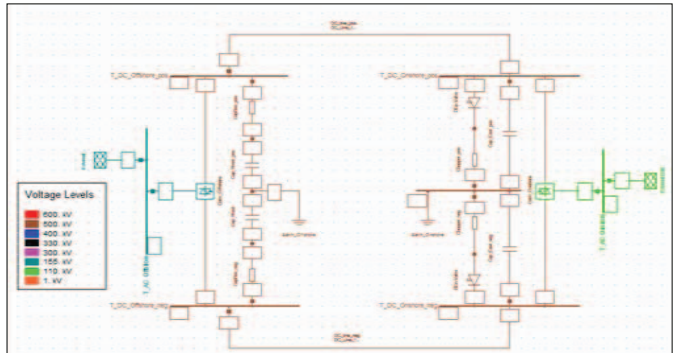

Fig. 8. VSC HVDC model on DigSILENT

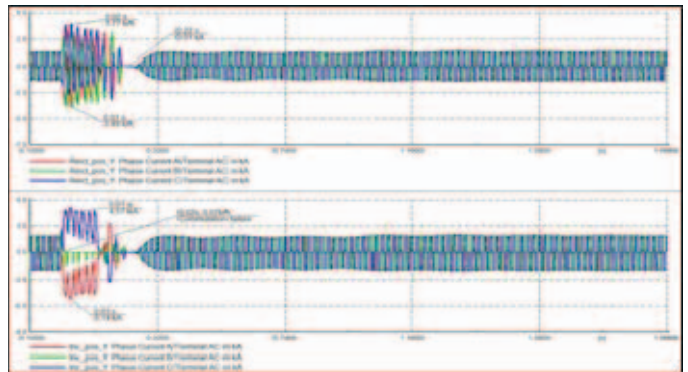

Fig. 9. LCC HVDC converter current during fault

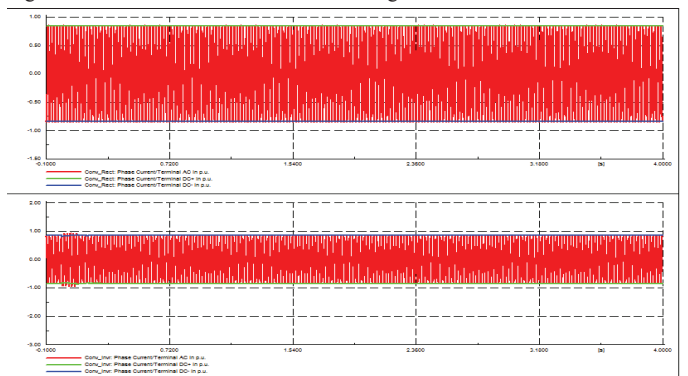

Fig. 10. VSC-Converter current

To study these responses, the AC busbar at the inverter side is subjected to a three-phase short circuit of  $10\Omega$  fault impedance for 200ms using the time domain simulation (EMT). After the EMT simulation, fig. 9 shows the graphic subplots for the current waveforms of the converter. During

fault, each converter controller helps in alleviating the effect of the fault on the converter. Like in the case of LCC, the voltage current order limiter (VDCOL) in the rectifier controller help to reduce the dc current, which in turn aid the inverter side to regain fast from commutation problem.

Fig. 10 shows subplot for VSC HVDC, during three-phase AC fault on the inverter busbar with little or no impact of the AC fault on the converter operation. This subplot shows that VSC HVDC system is immune to AC fault.

Different fault analysis which has been carried out on both two technologies on ability to reduce switching surge overvoltage and power systems restoration after blackout was discussed in [43]. The use of LCC-HVDC for different purposes, such as to improved voltage stability, transient and rotor angle stability was discussed in [44-47], while [48-50] talks on the new hybrid multi-level converter (alternate-Arm multi-level) with half-bridge multi-level benefit of low distortion, losses and full H-bridge converter benefit of DC-side fault blocking capability. The alternate-Arm multi-level discussed also have the ability to supply reactive during severe abnormal operation. This makes it more useful for AC grid during fault since it can provide reactive power support during voltage instability.

## VI. FUTURE TREND

VSC HVDC has more technical advantages than the contemporary LCC HVDC being a new method of HVDC transmission technology. The future trend in the development of this technology is likely to lead to a more efficient and cheaper use of VSC-HVDC. With an ongoing, never ceasing improvement, research and development on VSC-HVDC technology, especially in the area of converter design and topology, such breakthrough will surely contribute to the spread of VSC-HVDC transmission systems with overhead lines and accelerate the practical realization of HVDC networks that use voltage source converter technology.

Future trends also include the manufacturing of better power cable with higher voltage rating for VSC HVDC transmission. 320XLPE HVDC are still the maximum rating in service. But with ongoing research on power cables with high power rating and reduced cost, this will bring about more attraction to VSC-HVDC technology.

The use of VSC HVDC will continue to increase and apply to different power system interconnections at higher dc voltage and power rating.

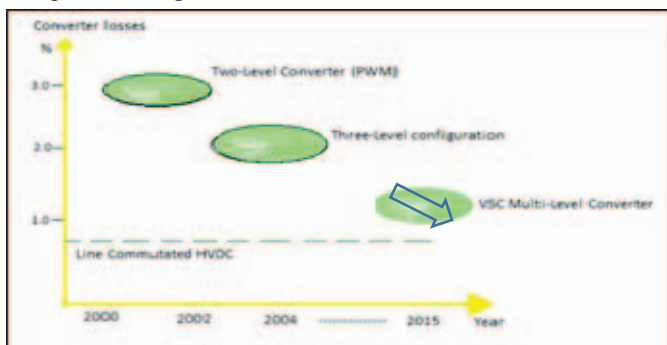

Fig. 11. LCC and VSC power loss

Fig. 11 shows the earlier stage of VSC based HVDC converter technology with much power losses. But due to the development in the converter and control technology, the present VSC-based HVDC technology is of lower magnitude. But with the introduction of the multi-level VSC configuration, this has significantly narrow the gap between LCC and VSC HVDC schemes.

## VII. CONCLUSION

The two dominant HVDC transmitting technology have been reviewed in this paper. Power electronics being the building block of any converter station, and the efficiency of these two technologies depend in the converter topology and the switches (semiconductors) used in fabricating them. LCC has the highest power rating and can sustain better during faults. However, for power control, flexibility and high converter efficiency, the VSC is superior. Though with this trend, LCC may remain the more utilized of these technologies in the foreseeable future due to its high reliability and well established thyristors base technology that it utilizes, but with the improvement in VSC technology and the advantages which it offers over LCC, VSC is bound to grow, and gain more recognition and market share, especially with the large-scale renewable energy integration into traditional AC power grids going on worldwide.

## REFERENCES

- [1] S. Shah, R. Hassan, and S. Jian, "HVDC transmission system architectures and control - A review," in Control and Modeling for Power Electronics, 2013 IEEE 14th Workshop on, 2013, pp. 1-8.
- [2] N. M. Kirby, "HVDC system solutions," in Transmission and Distribution Conference and Exposition T&D, IEEE PES, 2012, pp. 1-3.
- [3] M. H. Okba, M. H. Saied, M. Z. Mostafa, and T. M. Abdel-Moneim, "High voltage direct current transmission - A review, part I," in Energytech, 2012 IEEE, 2012, pp. 1-7.
- [4] R. Radzuan, M. A. A. Raop, M. K. M. Salleh, M. K. Hamzah, and R. A. Zawawi, "The designs of low power AC-DC converter for power electronics system applications," in Computer Applications and Industrial Electronics, IEEE Symposium on, 2012, pp. 113-117.
- [5] N. Florentzou, V. G. Agelidis, and G. D. Demetriades, "VSC-Based HVDC Power Transmission Systems: An Overview," Power Electronics, IEEE Transactions on, vol. 24, pp. 592-602, 2009.
- [6] M. P. Bahrman, "HVDC transmission overview," in Transmission and Distribution Conference and Exposition, 2008;IEEE/PES, 2008, pp. 1-7.
- [7] H. K. Müller, S. S. Torbaghan, M. Gibescu, M. M. Roggenkamp, and M. A. M. M. van der Meijden, "The need for a common standard for voltage levels of HVDC VSC technology," Energy Policy, vol. 63, pp. 244-251, 12// 2013.
- [8] L. de Andrade and T. P. de Leao, "A brief history of direct current in electrical power systems," in HISTory of ELectro-technology CONFERENCE (HISTELCON), 2012 Third IEEE, 2012, pp. 1-6.
- [9] S. M. Yousuf and M. S. Subramanian, "HVDC and Facts in Power System," International Journal of Science and Research, vol. 2, 2013.
- [10] B. K. Bose, "Evaluation of modern power semiconductor devices and future trends of converters," Industry Applications, IEEE Transactions on, vol. 28, pp. 403-413, 1992.
- [11] S. Tamai, "High power converter technologies for saving and sustaining energy," in Power Semiconductor Devices & IC's (ISPSD), 2014 IEEE 26th International Symposium on, 2014, pp. 12-18.
- [12] E. Kontos, R. T. Pinto, S. Rodrigues, and P. Bauer, "Impact of HVDC Transmission System Topology on Multiterminal DC Network Faults," Power Delivery, IEEE Transactions on, vol. 30, pp. 844-852, 2015.
- [13] M. Jafar and M. Molinas, "A transformerless series reactive/harmonic compensator for line-commutated HVDC for grid integration of offshore



- wind power," *Industrial Electronics, IEEE Transactions on*, vol. 60, pp. 2410-2419, 2013.
- [14] T. N. Tran, L. Luo, J. Xu, S. Dong, Z. Zhang, Z. Zhao, et al., "Analysis of the characteristics of the new converter transformer based on the matrix model," *Power Delivery, IEEE Transactions on*, vol. 27, pp. 821-830, 2012.
- [15] J. Vobecky, "The current status of power semiconductors," *Facta Universitatis, Series: Electronics and Energetics*, vol. 28, pp. 193-203, 2015.
- [16] M. Schenk, J. Przybilla, U. Kellner-Werdehausen, R. Barthelmess, J. Dorn, G. Sachs, et al., "State of the Art of Bipolar Semiconductors for Very High Power Applications,"; *Proceedings of International Exhibition and Conference for Power Electronics, Intelligent Motion, Renewable Energy and Energy Management*, Europe 2015, pp. 1-8.
- [17] J. Vobecky, V. Botan, K. Stiegler, U. Meier, and M. Bellini, "A novel ultra-low loss four inch thyristor for UHVDC," in *Power Semiconductor Devices & IC's, IEEE 27th International Symposium*, 2015, pp. 413-416.
- [18] C. Guo, Y. Liu, C. Zhao, X. Wei, and W. Xu, "Power Component Fault Detection Method and Improved Current Order Limiter Control for
- [19] H. Jingbo, L. Mingjie, Y. Jun, C. Qing, X. Tao, and Y. Zhao, "Research on dynamic characteristics and countermeasures of AC-DC hybrid power system with large scale HVDC transmission," in *Power System Technology (POWERCON), 2014 International Conference on*, 2014, pp. 799-805.
- [20] Anonymous, "HVDC Project List," Prepared for HVDC and Flexible AC transmission subcommittee of the IEEE Transmission and Distribution Committee, March 2012.
- [21] Y. Jiang-Hafner, H. Duchon, M. Karlsson, L. Ronstrom, and B. Abrahamsson, "HVDC with voltage source converters-a powerful standby black start facility," in *Transmission and Distribution Conference and Exposition, 2008; D. IEEE/PES, 2008*, pp. 1-9.
- [22] K. Friedrich, "Modern HVDC PLUS application of VSC in Modular Multilevel Converter topology," in *Industrial Electronics (ISIE), 2010 IEEE International Symposium on*, 2010, pp. 3807-3810.
- [23] J. Luo, J. Yao, D. Wu, C. Wen, S. Yang, and J. Liu, "Application research on VSC-HVDC in urban power network," in *Power Engineering and Automation Conference (PEAM), 2011 IEEE, 2011*, pp. 115-119.
- [24] M. Callavik, P. Lundberg, and O. Hansson, "NORDLINK Pioneering VSC-HVDC interconnector between Norway and Germany," March 2015.
- [25] V. Gelman, "Insulated-Gate Bipolar Transistor Rectifiers: Why They Are Not Used in Traction Power Substations," *Vehicular Technology Magazine, IEEE*, vol. 9, pp. 86-93, 2014.
- [26] O. Abarrategui, D. Larruskain, I. Zamora, V. Valverde, G. Buigues, and A. Iturregi, "VSC-based HVDC System Capability to Ride Through Faults," *International Conference on Renewable Energy and Power Quality*, 2015.
- [27] F. Shewarega and I. Erlich, "Simplified Modeling of VSC-HVDC in Power System Stability Studies," *International Federation of Automatic Control*, Cape Town, South Africa, 2014.
- [28] C. C. Davidson and D. Trainer, "Innovative concepts for hybrid multilevel converters for HVDC power transmission," in *AC and DC Power Transmission. 9th IET International Conference on*, 2010, pp. 1-5.
- [29] R. Marquardt, "Modular Multilevel Converter: An universal concept for HVDC-Networks and extended DC-Bus-applications," in *Power Electronics Conference (IPEC), 2010 International, 2010*, pp. 502-507.
- [30] T. Guangfu, H. Zhiyuan, and P. Hui, "R&D and application of voltage sourced converter based high voltage direct current engineering technology in China," *Journal of Modern Power Systems and Clean Energy*, vol. 2, pp. 1-15, 2014.
- [31] P. Hurtuk, R. Radvan, and M. Frivaldský, "Investigation of possibilities to increasing efficiency of full bridge converter designed for low output voltage and high output current applications," in *ELEKTRO, 2012*, 2012, pp. 129-132.
- [32] R. Marquardt, "Modular Multilevel Converter topologies with DC-Short circuit current limitation," in *Power Electronics and ECCE Asia, 2011 IEEE 8th International Conference on*, 2011, pp. 1425-1431.
- [33] H. Abu-Rub, J. Holtz, J. Rodriguez, and G. Baoming, "Medium-voltage multilevel converters—State of the art, challenges, and requirements in industrial applications," *Industrial Electronics, IEEE Transactions on*, vol. 57, pp. 2581-2596, 2010.
- [34] G. P. Adam, S. J. Finney, A. M. Massoud, and B. W. Williams, "Capacitor balance issues of the diode-clamped multilevel inverter operated in a quasi two-state mode," *Ieee Transactions on Industrial Electronics*, vol. 55, pp. 3088-3099, Aug 2008.
- [35] E. Najafi and A. H. M. Yatim, "Design and implementation of a new multilevel inverter topology," *Industrial Electronics, IEEE Transactions on*, vol. 59, pp. 4148-4154, 2012.
- [36] Y. Zhang, G. P. Adam, T. C. Lim, S. J. Finney, and B. W. Williams, "Analysis of modular multilevel converter capacitor voltage balancing based on phase voltage redundant states," *Iet Power Electronics*, vol. 5, pp. 726-738, 2012.
- [37] M. Glinka and R. Marquardt, "A new AC/AC multilevel converter family," *Industrial Electronics, IEEE Transactions on*, vol. 52, pp. 662-669, 2005.
- [38] A. Lesnicar and R. Marquardt, "An innovative modular multilevel converter topology suitable for a wide power range," in *Power Tech Conference Proceedings, 2003*, p. 6.
- [39] G. P. Adam, O. Anaya-Lara, G. M. Burt, D. Telford, B. W. Williams, and J. R. McDonald, "Modular multilevel inverter: pulse width modulation and capacitor balancing technique," *IET Power Electronics*, vol. 3, pp. 702-715, 2010.
- [40] G. Adam and I. Davidson, "Robust and Generic Control of Full-Bridge Modular Multilevel Converter High-Voltage DC Transmission Systems," in *IEEE Power electronic transaction*, 2015.
- [41] S. Qiang, L. Wenhua, L. Xiaoqian, R. Hong, X. Shukai, and L. Licheng, "A Steady-State Analysis Method for a Modular Multilevel Converter," *Power Electronics, IEEE Transactions on*, vol. 28, pp. 3702-3713, 2013. M. Glinka and R. Marquardt, "A new AC/AC multilevel converter family," *Industrial Electronics, IEEE Transactions on*, vol. 52, pp. 662-669, 2005.
- [42] Eskom, *HVDC Power Transmission: Basic Principles, Planning and Converter Technology (Part 1)*: Crown Publication cc., 2012.
- [43] G. P. Adam, S. Finney, K. Bell, and B. Williams, "Transient capability assessments of HVDC voltage source converters," in *Power and Energy Conference at Illinois (PECI), 2012 IEEE, 2012*, pp. 1-8.
- [44] K N I Mbangula, O. E. Oni and I E Davidson, "The Impact of HVDC Schemes on Network Transient Rotor Angle Stability," *24th Southern African Universities Power Engineering Conference*, South Africa January 2016.
- [45] O. E. Oni, K N I Mbangula, and I. E Davidson "Voltage Stability Improvement of a Multi-Machine System using HVDC", in press, *IEEE power system conference*, USA, March 2016.
- [46] K N I Mbangula and I E Davidson, "Detailed power system transient stability analysis using expert system concepts and stability improvement of a large multi-machine HVAC network using HVDC technologies," *Proceedings of the 23rd South African Universities Power Engineering Conference*, South Africa, January 2015.
- [47] K N I Mbangula, I E Davidson and R Tiako, "Improving Power System Stability of South Africa's HVAC Network Using Strategic Placement of HVDC Links". *Proceedings of the CIGRE International Symposium 2015 Development of Electricity Infrastructures for Sub-Saharan Africa*, Cape Town, South Africa, October 26-30, 2015.
- [48] M. Merlin, T. Green, P. D. Mitcheson, D. Trainer, D. Critchley, and R. Crookes, "A new hybrid multi-level voltage-source converter with DC fault blocking capability," in *AC and DC Power Transmission, 2010. ACDC. 9th IET International Conference on*, 2010, pp. 1-5.
- [49] G. P. Adam, K. H. Ahmed, S. J. Finney, K. Bell, and B. W. Williams, "New Breed of Network Fault-Tolerant Voltage-Source-Converter HVDC Transmission System," *IEEE Transactions on Power Systems*, vol. 28, pp. 335-346, Feb 2013.
- [50] N. Nayak, S. K. Routray, and P. K. Rout, "A robust control strategies to improve transient stability in VSC-HVDC based interconnected power systems," in *Energy, Automation, and Signal (ICEAS), 2011 International Conference on*, 2011, pp. 1-8.