

MODEL BASED REAL TIME CONTROLLER PERFORMANCE ASSESSMENT FOR NONLINEAR SYSTEMS

N. PILLAY & P. GOVENDER
DURBAN UNIVERSITY OF TECHNOLOGY

Abstract

The aim of this paper is to present a novel methodology for the performance assessment of proportional-integral-derivative (PID) controllers operating in the presence of process nonlinearities. The principle objective is to assess the quality of controller performance in real time when subjected to setpoint changes. Using prescribed operating regions, optimal PID controller settings are synthesized off-line by numerical optimisation from a trained artificial neural network (ANN) of the process. To demonstrate the effectiveness of the proposed controller benchmarking scheme, the procedure is applied to a simulation example, plus a real process control loop operating in a full scale pH neutralization pilot plant. Results obtained from the experiments indicate that the method is suitable for servo tracking in nonlinear control loops such as those found in the pulp and paper, and water purification industries.

Keywords: Performance assessment, artificial neural network, PID controller

1. INTRODUCTION

In modern industrial and process control there are many control loops which operate using the conventional proportional-integral-derivative (PID) controller (Agrawal & Lakshminarayanan, 2003). This is attributed to its simple and flexible control algorithm, low cost and effectiveness in linear systems. These controllers are often initially designed to meet some desired performance objectives but often fail when severe process nonlinearities are encountered. Many complex factors can contribute to gradual or abrupt performance deterioration such as control valve nonlinearities (Bacci di Capaci, Scali & Huang, 2016), sensor degradation and even intrinsic nonlinear process dynamics (Jelali, 2012). Performance evaluation is thus important and must be conducted regularly to ensure proper functioning of the controller design during the life cycle of the control loop (Veronesi & Visioli, 2015). Furthermore, continuous monitoring of plants has become increasingly relevant since poorly performing control loops contribute negatively from an economic and safety perspective (Srinivasan, Spinner & Rengaswamy, 2012).

The emerging area of controller performance assessment (CPA) determines controller performance by assessing and detecting the 'health' of a control loop (Jelali, 2012). Whilst there are well established CPA tools available, most

of them assume the process dynamics can be represented by a linear model (Harris & Yu, 2007). Notable research conducted by Harris (1989) has paved the way for more complex CPA algorithms which are discussed in Harris, Seppala & Desborough (1999) and Jelali (2012). Harris showed that the philosophy of minimum variance (MV) control can be used as a benchmark for closed loop performance assessment (Harris, 1989). The idea is central to many other performance measures found in literature and has been extended to evaluate controllers designed for cascade, feedforward and multivariate systems. Whilst MV is an important lower performance bound, it does not take into consideration the structure of the controller and may be regarded as an overly ambitious index when PID type control structures are concerned (Yu, Wilson, Young & Harris, 2009).

For nonlinear systems that can be adequately described by Volterra models, Harris and Yu (2007) showed that MV performance estimation is only possible through the existence of feedback invariance from routine plant operating data. Feedback invariance is the dynamic part of a closed loop system that is not affected by feedback for that specific sampling instant. For linear systems, the feedback invariance can be easily recovered from the process closed loop time series; however this is not the case for general dynamic nonlinear systems as discussed by Harris and Yu (2007). To avoid this limitation of the aforementioned MV lower bound, Yu, *et al.* (2009) suggested an alternative strategy using variance decomposition based on the analysis of variance of Nonlinear AutoRegressive Moving Average with eXogenous (NARMAX) input models. Closed loop identification of the NARMAX model and initial conditions are a requirement for computing the index.

Nonlinear controller performance assessment (NLCPA) in the presence of moderate control valve stiction was discussed in Yu, Wilson & Young (2010), where spline smoothing is applied to remove the nonlinearity caused by valve stiction prior to estimating the MV index. For this case, an alternate approach is proposed which takes advantage of steady state periods when the feedback loop is ineffective due to the 'stuck' valve. By exploiting these steady state periods, it is possible to compute the MV benchmark. Finally it was shown by Yu, Wilson & Young (2012) that disregarding any nonlinearity present in the control loop may lead to an erroneous loop performance estimate. Therefore it is important to account for any nonlinearity when estimating controller closed loop performance. For the case of setpoint tracking, researchers (cf. Swanda & Seborg, 1999 ; Yu, Wang, Huang, & Bi, 2011) have proposed controller performance benchmarking indices which are based on linear process models. Significant interest has been shown towards restricted structured controllers operating under system constraints which allow for realistic performance benchmarks. Thus the contribution of this work is to present a methodology to extend NLCPA of gain scheduling PID controllers that are designed to operate for setpoint tracking in general nonlinear dynamic processes.

2. DEVELOPMENT OF THE CONTROLLER BENCHMARK METHODOLOGY

2.1 CPA for nonlinear systems

Consider the negative feedback single-input-single-output (SISO) closed loop control system under performance inspection illustrated in Figure 1.

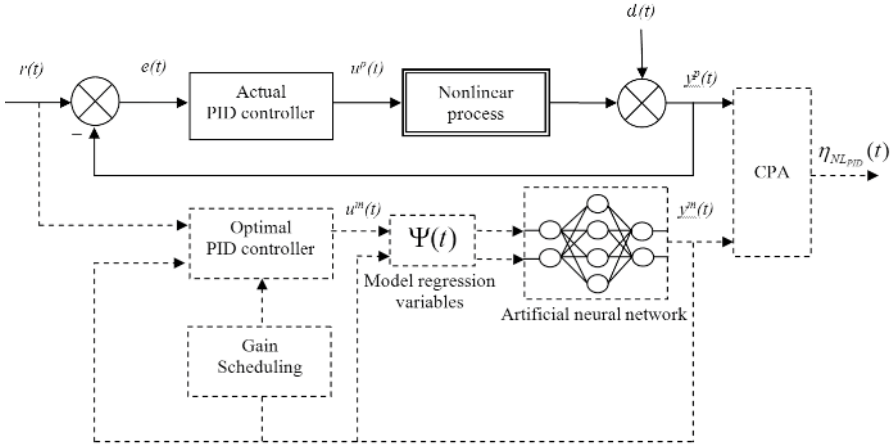

Figure 1. Controller performance assessment scheme for SISO nonlinear process.

The basic idea is to compare the closed loop performance of the actual controller to that of an optimal controller designed offline for the generalized nonlinear process. For the purpose of comparison, an open loop model of the nonlinear process is required. In this paper, we utilize artificial neural networks (ANNs) for modeling open loop nonlinear system dynamics. The characteristics of neural networks suggest that they are useful in their ability to represent arbitrary nonlinear mappings (Lightbody & Irwin, 1997). This encourages their use for NLCPA.

For this study we consider SISO negative feedback systems; however the approach can be readily extended to multivariable systems, plus model based and feed forward control strategies. Procedures for estimating the nonlinear restricted structure performance bound $\eta_{NL_PID}(t)$ are discussed in the subsequent sections.

2.2 Nonlinear plant identification (stage 1)

In order to establish a suitable performance benchmark we first train a neural network to capture relationships between the actual plant input $u^p(t)$ and its corresponding output $y^p(t)$. Later, the trained ANN is used in the design of optimal controllers and for real time estimation of a synthetic process output $y^m(t)$ under closed loop conditions for the NLCPA procedure. A nonlinear discrete time process of a neural network based NARMAX model is considered:

$$y^p(t) = f[y(t-1), \dots, y(t-n_y), u(t-1), \dots, u(t-n_u)] + d(t) \quad (1)$$

With regards to (1), the process output $y^p(t)$ can be evaluated in terms of a nonlinear function $f(\cdot)$ of the past output and input values denoted by $y(t-1)$ and $u(t-1)$ respectively, in which n_y and n_u are the corresponding lag terms; $d(t)$ denotes the disturbance noise signal affecting the process output. An appropriate excitation signal will drive the system in order to capture its nonlinear behavior. It is important that the input signal is adequate for capturing the system's dynamics over its entire operating range of interest. This stage of the procedure is repeated if process changes occur. A suitably trained ANN is capable of mapping the nonlinear relationship $f(\cdot)$, thus replicating actual process output behavior for a given input signal. If identification is satisfactory, the model residual error will be unpredictable and uncorrelated with its past inputs and outputs. For these conditions, the residual error can be used for model validation (Chen, Billings & Grant, 1990). Expressing Eq.(1) in terms of a deterministic model yields:

$$y^m(t) = NNARMAX(\Psi(t)) \quad (2)$$

where $y^m(t)$ is the instantaneous value of the neural NARMAX (NNARMAX) system output. The regression vector is defined as:

$$\Psi(t) = [y(t-1), \dots, y(t-n_y), u(t-1), \dots, u(t-n_u)]^T \quad (3)$$

NARMAX models have been widely studied and applied to nonlinear system identification (Chen, *et al.*, 1990; Bittani & Pirrodi, 1997). In this study, a multilayer feed forward ANN structure with hidden layers is utilized to approximate a NARMAX process model structure. The ANN's free parameters are adjusted during offline supervised training to minimize the sum squared error performance measure. An ANN model can be used to obtain linearized models for optimal PID parameter determination. Well established design methodologies can be applied to linearized systems for optimal controller design.

Separate linearized models are necessary for different operating regions. A linearized model at any operating region may be represented as:

$$y(t)A(z) = B(z)u(t - n_k) \quad (4)$$

With regards to (4), Z^{-1} is the delay operator and a_n, b_n are the polynomial coefficients; polynomials $A(z)$ and $B(z)$ are given as:

$$A(z) = 1 + a_1 z^{-1} + \dots + a_{n_y} z^{-n_y}$$

$$B(z) = b_1 z^{-1} + b_2 z^{-2} + \dots + b_{n_u} z^{-n_u+1}$$

The system discrete dead-time by which the input signal affects the output is denoted by n_k . For a desired operating point (t_{OP}), the first partial derivative term can be used.

$$a_i = -\frac{\partial NNARMAX}{\partial y(t-i)} \Big|_{\Psi(t)=\Psi(t_{OP})} \quad i = 1, 2, \dots, n_y \quad (5)$$

$$b_i = \frac{\partial NNARMAX}{\partial u(t-i)} \Big|_{\Psi(t)=\Psi(t_{OP})} \quad i = 1, 2, \dots, n_u$$

With regards to (5), a_i and b_i ; $y(t)$ and $u(t)$ denote the output and input signals, respectively.

2.3 Optimal PID controller design (stage 2)

One form of a linear PID controller is as follows:

$$u(t) = k_c \left[e(t) + \frac{1}{\tau_i} \int_0^t e(t) dt + \tau_d \frac{de(t)}{dt} \right] \quad (6)$$

where the instantaneous control loop error, $e(t) = r(t) - y(t)$ is deviation of the process output from the setpoint; k_c , τ_i and τ_d represent the proportional gain, integral time constant and the derivative time constant, respectively. Adopting a discrete time PID version of Eq.(6) gives the velocity form at each sample point T_s :

$$u(t) = u(t-1) + k_c \left[\left[(e(t) - e(t-1)) + \frac{T_s}{\tau_i} e(t) + \frac{\tau_d}{T_s} [e(t) - 2(e(t-1)) + e(t-2)] \right] \right] \quad (7)$$

For a particular preselected sampling time the objective is to determine the best values of k_c , τ_i and τ_d that will result in optimal control in terms of the integrated absolute error (IAE) performance measurement. Variations of nonlinear PID architecture are found on industrial controllers from different manufacturers. Tuning of the controller for nonlinear systems is accomplished through numerical optimization.

The NLCPA benchmark will give an indication of control health when the performance of the real-time controlled plant is compared to that of an optimal gain scheduler controlling an ANN model of the nonlinear process.

Matlab® is a popular software environment used by many researchers for offline controller design (Sendjaja & Kariwala, 2009; Agrawal & Lakshminarayanan, 2003). In this paper, a hybrid Nelder Mead-Particle Swarm Optimization (NM-PSO) function is utilized to determine optimal controller parameters. The NM simplex algorithm (Nelder & Mead, 1965) is a widely used numerical method for solving nonlinear unconstrained optimization problems. The objective of the algorithm is to minimize a cost function without any derivative information.

The PSO method, developed by Eberhart and Kennedy (1995), is based on the concept of social interactions that exists in nature. The technique is highly stochastic and is population based which can search a large feature space without succumbing to the effects of local minima for which the NM is prone to. By combining the stochasticity of the PSO and the local search capabilities of the NM optimization, the hybrid NM-PSO is proficient in determining global optimal controller parameters. Further details of the hybrid optimization algorithm can be found in Pillay and Govender (2013).

During the controller design, step responses of the closed loop system for different operating conditions are simulated and the optimal controller parameters are determined using the NM-PSO algorithm to solve the objective function:

$$J_{k_c, \tau_i, \tau_d} = \min \sum |r(t) - y^m(t)| \quad (8)$$

with the following inequalities imposed:

$$y^m_{\min} < y^m < y^m_{\max} \quad (9)$$

$$k_{c_{\min}} < k_c < k_{c_{\max}} \quad (10)$$

$$\tau_{i_{\min}} < \tau_i < \tau_{i_{\max}} \quad (11)$$

$$\tau_{d_{\min}} < \tau_d < \tau_{d_{\max}} \quad (12)$$

These constraints ensure that the simulated process output will not exceed the prescribed operating points and the controller parameters will not lead to excessive values which if applied on a real PID controller may lead to excessive final control element wear. A scheduling variable is chosen and adjusted accordingly for each operating condition.

Once the optimal values are determined for each operating region, it can be used on the simulated PID algorithm to obtain $u^m(t)$ in a generalized gain scheduling scheme. Since performance evaluation of the PID controller is the central theme of this work, the linear intuitive gain scheduling method represents a convenient approach for PID implementation in nonlinear control problems (Rugh & Shamma, 2000).

2.4 Controller performance index (stage 3)

In the final stage of the methodology we use the NNARMAX model obtained from open loop system identification experimentation, and the optimal PID controller parameters computed for each operating point in the real time estimation of the NLCPA. By computing the closed loop response of the gain scheduled optimal PID controller in series with the NNARMAX model we can obtain an artificial process output $y^m(t)$. To establish the real time performance index, we use the synthetic signal of the simulated process output and compare it to the actual plant process variable $y^p(t)$. The desired reference trajectory $r(t)$ is mutual to the simulated PID control and the real PID process controller as indicated in Figure 1. A novel dynamic performance assessment benchmark that relates current controller performance to an optimal gain scheduled nonlinear PID controlled system is given as:

$$\eta_{NL_{PID}} = 1 - \frac{\sum_t^{t+w} |r(t) - y^m(t)|}{\sum_t^{t+w} |r(t) - y^p(t)|} \quad (13)$$

where w is the length of the moving window used to provide continuous update on the current controller performance and is a user defined parameter. An illustration of the moving window of the real and artificial process outputs is shown in Figure 2. The proposed NLCPA index is bound in the range, $0 < n_{NL_{PID}} < 1$ where $n_{NL_{PID}} \rightarrow 0$ would indicate good control; conversely if, $n_{NL_{PID}} \rightarrow 1$ the actual closed loop performance is regarded as poor relative to the modeled process output.

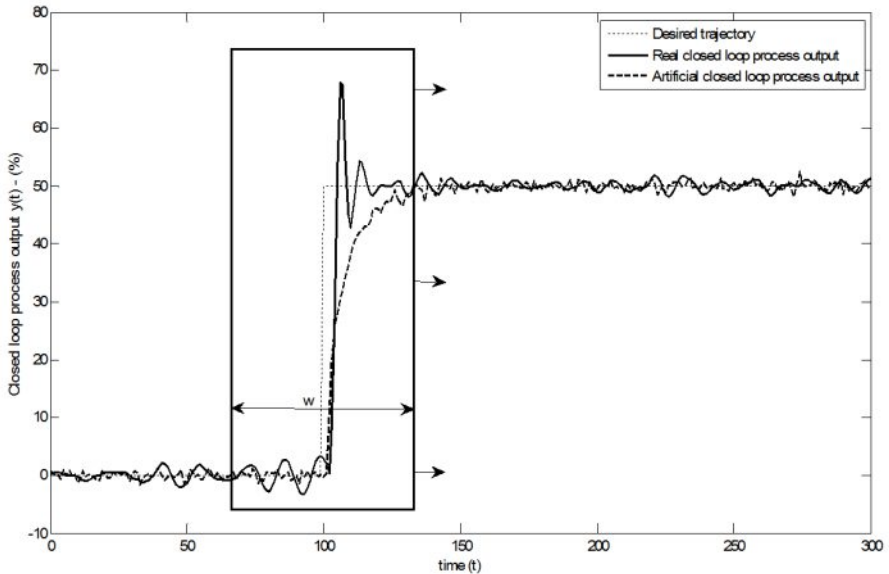

Figure 2. Real time performance assessment based on running window IAE.

3. ILLUSTRATIVE EXAMPLES

3.1 Preliminaries to the experiments

The output from a real world pH plant and a simulated system are necessary to assess the performance of the NLCPA index. The MATLAB System Identification Toolbox[®] was used to determine open loop nonlinear discrete models for all the presented examples. A unit step-up and unit step-down input signal with equal magnitude was injected into the processes for the purpose of capturing nonlinear system dynamic behaviors. A NNARMAX feedforward model having three hidden layers of 10, 20 and 15 neurons with corresponding sigmoid, sigmoid and linear activation functions respectively was used to develop the process model.

Two operating points was chosen for obtaining linearized models at the prescribed operating region to demonstrate the methodology. Corresponding linearized transfer functions (Eq.4) was used in the computation of determining optimal PID controller settings that minimize Eq.(8). Constraints (Eqs. 9-12) imposed on the optimization are listed in Table 1. With regards to Table 1, the regression variables are based on the Akaike criterion (Akaike, 1974) and yielded the best fit for a linearized model; the controller parameters were determined intuitively. The limits on the outputs were chosen to encapsulate the best dynamic behavior of the process. The optimal controller settings in Table 2 are based on NM-PSO (Pillay & Govender, 2013).

Tests using a Volterra model and a real time pH system were conducted to assess the performance of the NLCPA. These are discussed in experiments 1-2.

Table 1. Constraints used in the determination of the optimal PID controller settings for respective operating points.

Case study	Constraints																
	Sample time	Regression variables			Limits on PID settings						Limits on process output						
		T_s (sec)	n_y	n_u	n_k	k_{min}	k_{max}	$\tau_{i_{min}}$ (sec)	$\tau_{i_{max}}$ (sec)	$\tau_{d_{min}}$ (sec)	$\tau_{d_{max}}$ (sec)	Operating point 1	Operating point 2	$y^{m_{min}}$	$y^{m_{max}}$	$y^{m_{min}}$	$y^{m_{max}}$
Simulated plant	1	2	2	1	0.0	1	0.1	10	0	0	0	0.5	0.5	1			
Real time pH control	1	2	2	1	0.1	10	100	1000	0	0	8.0	9.5	9.5	10.5			

Table 2. The optimal controller parameters for each case study at respective operating points

Case study	Optimal gain scheduling PI controller settings			
	Operating point 1		Operating point 2	
	k_c	τ_i	k_c	τ_i
Simulation	0.354	4.023	0.439	3.429
pH control	1.18	787	1.25	694

3.2 Hardware and OPC setup for real time experiments

To demonstrate real time NLCPA for the control loops operating in the pH neutralization pilot plant, an open process control (OPC) server was set up to transfer data from the distributed control system (DCS) to the MATLAB processing environment. ABB® AC700 control hardware was used in the real time control of the process plant and connected to an Intel i7 personnel computer with 4 megabytes of random access memory running MATLAB and ABB® Freelance software. The experimental setup used for the real process control loops is shown in Figure 3. The advantage of this scheme will allow for implementation of the NLCPA on an external system platform while computational power of the DCS is reserved for primary process control computations such as PID control and basic data manipulation.

Furthermore, the DCS platform is restricted to primitive function blocks and higher level programming tools (for example; system identification and optimization computation) are more suited to a separate computer system that is connected to the DCS through the OPC server (Hägglund, 2005). The proposed nonlinear performance index is computed in MATLAB and transmitted to the DCS in real time for presentation on the Human Machine Interface (HMI).

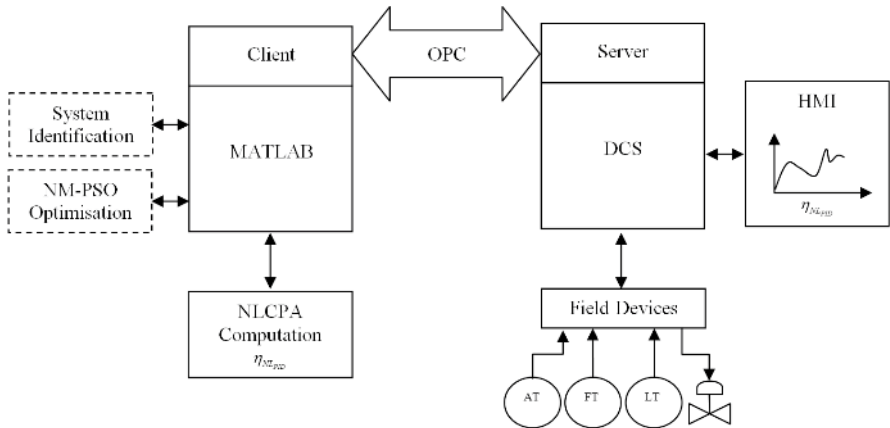

Figure 3. Connection between MATLAB and DCS using OPC for the experimental setup.

3.3 Example 1: Simulation case study

Consider a nonlinear dynamical system represented by a second order Volterra series given by (Harris & Yu, 2007):

$$y(t)^p = 0.2u(t-3) + 0.3u(t-4) + u(t-5) + 0.8u^2(t-3)u(t-4) - 0.7u^2(t-4) - 0.5u^2(t-5) - 0.5u(t-3)u(t-5) + d(t) \quad (14)$$

Where the disturbance $d(t)$ is defined as:

$$d(t) = \frac{a(t)}{1 - 1.6z^{-1} + 0.8z^{-2}} \quad (15)$$

and $a(t)$ is a zero mean white noise sequence with variance 0.1.

For our study, we compared the controller performance of an optimal PI gain scheduler scheme to that of a similar controller having suboptimal parameters. This was done in order to assess the efficacy of the NLCPA.

Optimal controller values are used in the gain scheduling scheme for the developed NLCPA methodology and the simulation results are shown in Figure 4(a).

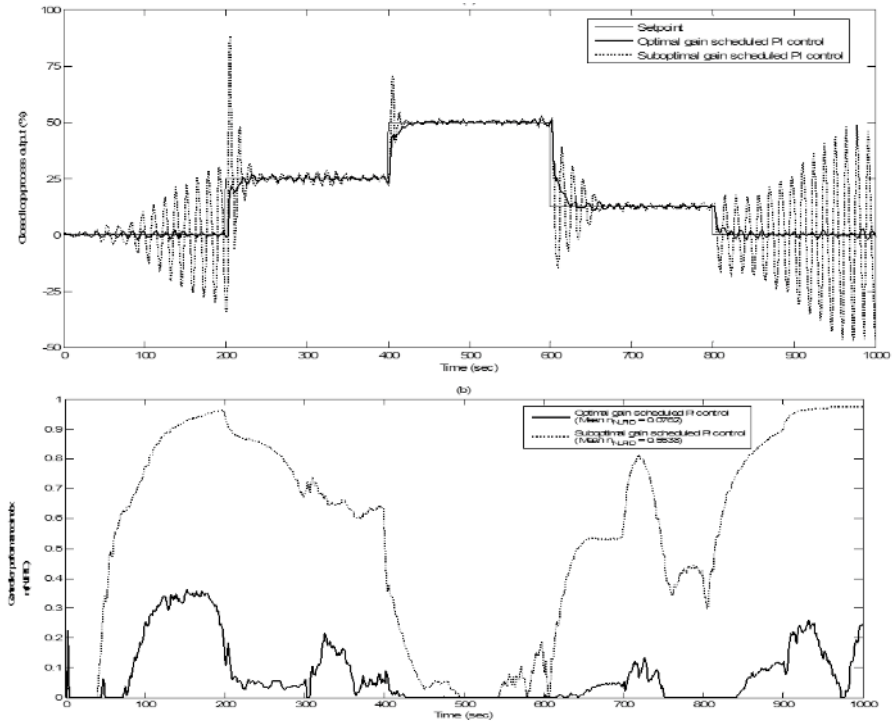

Figure 4. (a) Closed loop simulation following setpoint changes. (b) Dynamic NLCPA index for Example 1.

A comparative assessment was done to evaluate the performance of the optimal gain scheduled controller acting on the simulated process response y^m . It is observed from Figure 4(a) that the suboptimal gain scheduler yields excessive oscillations at setpoint $r(t)=0$, whilst acceptable control performance occurs at $r(t)=1$. This is so because of changes to process states for transitions of y^p .

From Figure 4(b), the variations in closed loop performance is clearly indicated by the proposed performance index given by Eq.(13) where at time $t = 200$ seconds, $n_{NL_{PID}} = 0.96$ and at time $t=900$ seconds the $n_{NL_{PID}} = 0.91$ with suboptimal gain scheduled control; the corresponding indices for the optimally tuned controller are $n_{NL_{PID}} = 0.13$ and $n_{NL_{PID}} = 0.12$ respectively. This was expected due to the inherent nonlinear behavioral characteristics of the process affecting control loop performance for setpoint changes.

3.4 Example 2: Real-time pH control case study

The control of pH is commonly encountered in many chemical, pharmaceutical and biotechnological industries in which tight control of the variable is sought (McMillan, 1994). It is often recognized as a challenging task due to the time varying behavior exhibited by many pH neutralization processes. Furthermore, these processes experience rapid transitions within the control channel which lead to changes in process gain over a small range of pH (Henson & Seborg, 1994).

In this example, we use the control of pH to demonstrate the application of the proposed NLCPA technique on an actual full scale pH neutralization pilot plant shown in Figure 5 and its corresponding process and instrumentation diagram (P&ID) illustrated in Figure 6. Regulation of pH according to a desired setpoint is of importance, where a strong alkaline solution (sodium hydroxide (NaOH)) is neutralized by a strong acidic solution [sulphuric acid (H_2SO_4)].

The reagents are mixed in a continuous stirred reactor (CSTR) with the level maintained at a steady state. Relevant CSTR parameters are listed in Table 3.

Table 3. pH neutralization plant parameters

Parameters of the CSTR	Value
Volume of the tank	125 liters
Steady state level of the tank	40%
Steady state flow rate of NaOH	2.5 liters/min
Range of pH setpoint change	8.5 – 10.5
Concentration of influent process stream, NaOH	32.1×10^{-3} mol./liter
Concentration of titrating stream, H_2SO_4	6.53×10^{-3} mol./liter



Figure 5. pH neutralization pilot plant housed in the Unit Optimization Studies Laboratory at the Durban University of Technology.

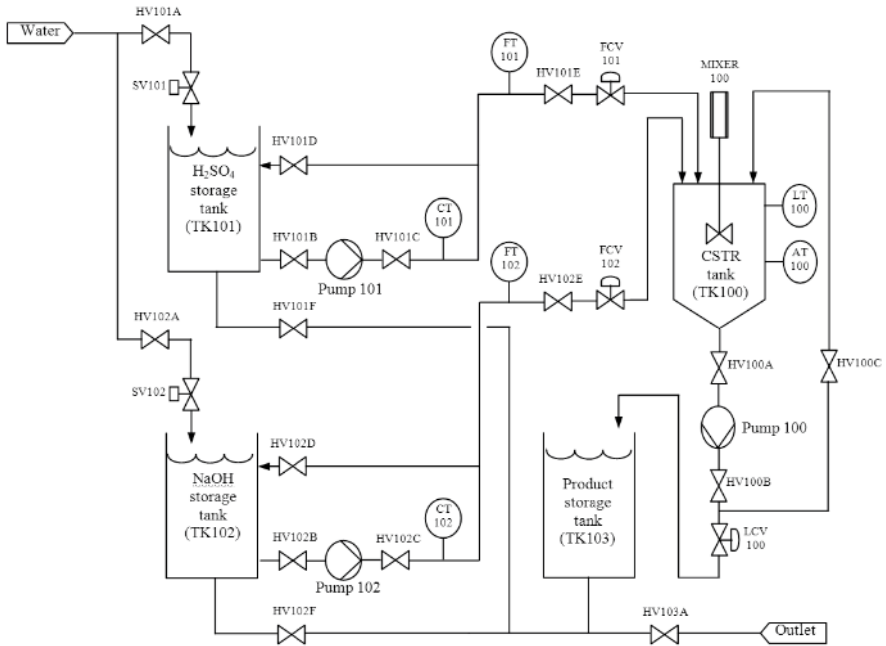

Figure 6. P&ID of the pH neutralization pilot plant.

The CSTR has two main inlet streams: the influent process stream (NaOH) and the titrating stream (H₂SO₄). Before being pumped into the effluent storage tank, a small percentage of effluent stream is directed back to the CSTR tank for efficient mixing.

The dominant problems associated with continuous control of pH are the varying nonlinear degrees of sensitivity of the chemical reaction, and the limiting capabilities of control hardware such as the rangeability of the control valve and poor process design (McMillan, 1994). Therefore, in order for the pH control system to work efficiently, special attention must be paid to the design and installation of pH electrodes, control valves, piping and mixing equipment. According to McMillan (1994), the pH process gain is dynamic and is influenced by changes in pH concentration for acid-base ratio changes within a CSTR. The dynamism of the pH variable is demonstrated in Figure 7(a) which illustrates the closed loop responses for a suboptimal gain scheduler and an optimized gain scheduling PI controller. The proposed NLCPA index is also shown in Figure 7(b) to indicate varying qualities of the control effort.

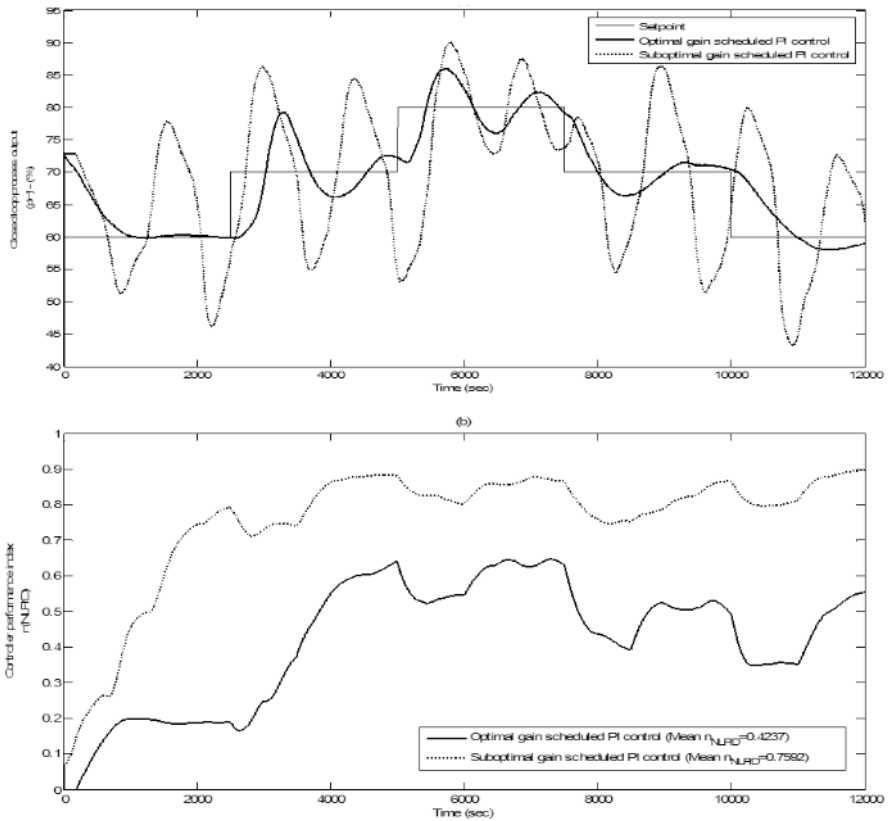

Figure 7. (a) Closed loop pH response following setpoint change for the suboptimal and optimal gain scheduled PI controllers. (b) Dynamic NLCPA index for Example 2.

As expected optimal gain schedule control yielded a superior control performance for changes in setpoint. Computed mean values of the performance index for the fixed and gain scheduled controllers are $n_{NL_{PID}} = 0.759$ and $n_{NL_{PID}} = 0.424$, respectively.

4. DISTRIBUTION ANALYSIS OF THE DYNAMIC NLCPA INDEX

To study the effects of different controller parameters on the distribution of $n_{NL_{PID}}$, T_i for each operating point was increased progressively for the simulation case study discussed in example 1. In this instance, T_i is chosen because of its substantial impact on the closed loop stability of the selected process. Figure 8 shows the kernel density estimates of the distribution of $n_{NL_{PID}}$ for variations in T_i .

From Figure 8, the optimal controller values for the nonlinear performance index shows a narrow distribution falling between 0 and 0.4. For increases in integral time, the distribution of n_{NL-PID} gets broader with a higher distribution of n_{NL-PID} approaching 1. Table 4 shows the variance from the mean of the closed loop error and the corresponding. It is observed that the optimal controller results in the lowest error variance and mean n_{NL-PID} with strong correlation as the controller integral time constant is increased. This indicates that the proposed nonlinear index is capable of detecting increasingly poor closed performance when the controller parameters deviate from optimal settings.

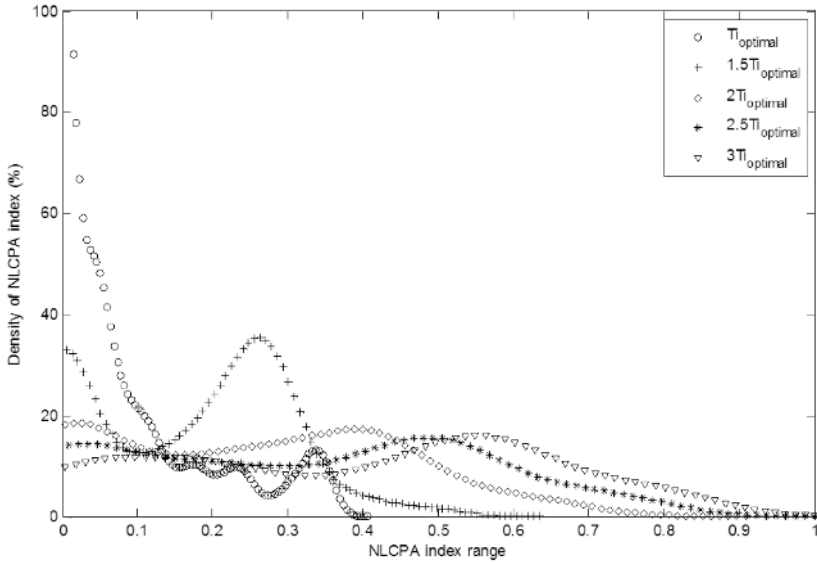

Figure 8. Kernel density estimates of n_{NL-PID} for Example 1 with varying τ_i values.

Table 4. Error indices and the mean controller performance index for increasing integral time constants from Example 1.

Deviation from optimal τ_i	Error Variance	Mean η_{NL-PID}
$\tau_{i\text{optimal}}$	5.522×10^{-3}	0.0763
$1.5\tau_{i\text{optimal}}$	6.823×10^{-3}	0.1642
$2\tau_{i\text{optimal}}$	8.233×10^{-3}	0.2427
$2.5\tau_{i\text{optimal}}$	9.681×10^{-3}	0.3141
$3\tau_{i\text{optimal}}$	11.14×10^{-3}	0.3846

5. CONCLUSIONS AND FUTURE WORK

This work has presented a methodology for real time controller performance estimation of SISO nonlinear control loops. The methodology is effective for determining acceptable and poor closed loop performance during setpoint changes. The technique has been successfully implemented online using an OPC server interface that establishes access of the process control loop signals from the DCS to a real time monitoring PC. This approach allows for convenient transfer of raw process data to the monitoring PC running the NLCPA tool. Using the proposed NLCPA index, simple high alarms can be setup for each process control loop to alert practitioners of unacceptable loop behavior.

An optimally tuned gain scheduler controller was chosen as a realistic benchmark for a broad class of nonlinear dynamic systems represented by the NNARMAX model. ANN models of simulated and real process systems were constructed using only I/O data. As with most designs that rely on a process model, insufficient and/or inapt data may lead to poor model estimation and will negatively impact on the NLCPA tool. It is therefore important for accurate model identification to determine optimal PID controller settings, since it is used directly in the real time benchmarking index. Furthermore, the methodology presented in this paper can be extended by incorporating the controller output variance with that of the process output within the controller design. Finally, the novel NLCPA index provides an alternative to the MVC benchmark and considers nonlinearities inherent in the control loop.

6. ACKNOWLEDGEMENT

This research has been supported by the National Research Foundation (NRF) of South Africa under grant number: TTK1206121201. Technical support from ABB® South Africa, Department of Control Technologies is gratefully appreciated.

7. REFERENCES

- Akaike, J. 1974. A New Look at the Statistical Model Identification. *IEEE Transaction on Automatic Control*. 19 (6): 716-723.
- Agrawal, P. & Lakshminarayanan, S. 2001. Tuning proportional-integral-derivative controllers using achievable performance indices. *Industrial & Engineering Chemistry Research*. 42(22): 5576-5582.
- Åström, K.J. & Häggglund, T. 1984. Automatic tuning of simple regulators with specifications on phase and amplitude margins. *Automatica*. 20(5): 645-651.

Bacci di Capaci, R., Scali, C. & Huang, B. 2016. A Revised Technique of Stiction Compensation for Control Valves. Proceedings of the 11th IFAC Symposium on Dynamics and Control of Process Systems, including Biosystems, Trondheim, Norway. June 6-8, 2016: 1038-1043.

Bittani, S. & Piroddi, L. 1997. Nonlinear Identification and Control of Heat Exchanger: A Neural Network Approach. Journal of the Franklin Institute. 334(1): 135-153.

Chen, S., Billings, S. & Grant, P. 1990. Non-linear system identification using neural networks. International Journal of Control. 51(6): 1191-1214.

Choudhury, M., Shah, L. & Thornhill, N. 2004. Diagnosis of poor control-loop performance using higher-order statistics. Automatica. 40(10): 1719-1728.

Eberhart, R. C. & Kennedy, J. 1995. A new optimizer using particle swarm theory. Proceedings of the 6th International Symposium on Micro Machine and Human Science, New York, United States of America, October 4-6, 1995: 39-43.

Hägglund, T. 2005. Industrial implementation of on-line performance monitoring tools. Control Engineering Practice. 13(11): 1383-1390.

Harris, T., Seppala, C. & Desborough, L. 1999. A review of performance monitoring and assessment techniques for univariate and multivariate control systems. Journal of Process Control. 9(1): 1-17.

Harris, T. & Yu, W. 2007. Controller assessment for a class of non-linear systems. Journal of Process Control. 17(7): 607-619.

Harris, T. J. 1989. Assessment of control loop performance. The Canadian Journal of Chemical Engineering. 67 (5): 856-861.

Henson, M. A. & Seborg, D. E. 1994. Adaptive nonlinear control of a pH neutralization process. IEEE Transactions on Control Systems Technology. 2(3): 169-182.

Jelali, M. 2012. An overview of control performance assessment technology and industrial applications. Control Engineering Practice. 14(5): 441-466.

Lightbody, G. & Irwin, G. W. 1997. Nonlinear Control Structures Based on Embedded Neural System Models. IEEE Transactions on Neural Networks. 8(3): 553-567.

McMillan, G. K. 1994. pH measurement and control. 2nd Edition. Cornell University. Instrument Society of America.

- Nelder, J. A. & Mead, R. 1965. A simplex method for function minimization., *The Computer Journal*. 7(4): 308-313.
- Pillay, N. & Govender, P. 2013. Constrained Minimum-Variance PID Control using Hybrid Nelder-Mead Simplex and Swarm Intelligence. In the Proceedings of the 5th International Conference on Agents and Artificial Intelligence, Barcelona, Spain, February 15-18, 2013: 330-337.
- Rugh, W. J. & Shamma, J.S. 2000. Research on Gain Scheduling. *Automatica*. 36 (10): 1401-1425.
- Sendjaja, A. Y. & Kariwala, V. 2009. Achievable PID performance using sums of squares programming. *Journal of Process Control*. 19 (6): 1061-1065.
- Srinivasan, B., Spinner, T. & Rengaswamy, R. 2012. Control loop performance assessment using detrended fluctuation analysis (DFA). *Automatica*. 48(7): 1359-1363.
- Swanda, A. P. & Seborg, D. E. 1999. Controller performance assessment based on setpoint response data. In the Proceedings of IEEE American Control Conference, San Diego, California, June 2-4, 1999: 3863-3867.
- Veronesi, M. & Visioli, A. 2015. Deterministic Performance Assessment and Retuning of Industrial Controllers Based on Routine Operating Data: Applications. *Processes*. 3(1), viewed 29 July 2016, from: <http://www.mdpi.com/2227-9717/3/1/113/htm>.
- Yu, W., Wilson, D., Young, B. & Harris, T. 2009. Variance decomposition of nonlinear systems. In the Proceedings of the IEEE International Conference on Control and Automation. Christchurch, New Zealand, December 9-11, 2009: 738-744.
- Yu, W., Wilson, D. & Young, B. 2010. Nonlinear control performance assessment in the presence of valve stiction. *Journal of Process Control*. 20 (6): 754-761.
- Yu, W., Wilson, D. & Young, B. 2012. A comparison of nonlinear control performance assessment techniques for nonlinear processes. *The Canadian Journal of Chemical Engineering*. 90 (6): 1442-1449.
- Yu, Z., Wang, J., Huang, B. & Bi, Z. 2011. Performance assessment of PID control loops subject to setpoint changes. *Journal of Process Control*. 21 (8): 1164-1171.